

Powerstock - Calorifier Range

Equipment For Commercial Potable Hot Water
Installations.

Installation, Commissioning and Servicing Instructions

IMPORTANT NOTE

**THESE INSTRUCTIONS MUST BE READ
AND UNDERSTOOD BEFORE INSTALLING,
COMMISSIONING, OPERATING OR
SERVICING EQUIPMENT**



Heating *at work.*

Customer After Sales Services

Telephone: **0845 450 2866** E-mail: **aftersales@hamworthy-heating.com** Fax: **01202 662522**

Technical Enquiries

To supplement the detailed technical brochures, technical advice on the application and use of products in the Hamworthy Heating range is available from our technical team in Poole and our accredited agents.

Site Assembly

Hamworthy offer a service of site assembly for many of our products in instances where plant room area is restricted. Using our trained staff we offer a higher quality of build and assurance of a boiler built and tested by the manufacturer.

Commissioning

Commissioning of equipment by our own engineers, accredited agents or specialist sub – contractors will ensure the equipment is operating safely and efficiently.

Maintenance Agreements

Regular routine servicing of equipment by Hamworthy service engineers inspects the safety and integrity of the plant, reducing the risk of failure and improving performance and efficiency. Maintenance agreements enable our customers to plan and budget more efficiently.

Breakdown service, repair, replacement

Hamworthy provide a rapid response breakdown, repair or replacement service through head office at Poole and accredited agents throughout the UK.

Spare Parts

A comprehensive spare parts service is operated from our factory in Poole, providing replacement parts for both current and discontinued products. Delivery of parts and components is normally from stock within seven days. However, a next day delivery service is available for breakdowns and emergencies.

Powerstock Calorifier

**Models PS160, PS200, PS300
PS400, PS500, PS750 & PS1000**

**INSTALLATION, COMMISSIONING AND
SERVICING INSTRUCTIONS**

**THE POWERSTOCK CALORIFIER IS INTENDED FOR USE AS A
COMMERCIAL APPLIANCE.**

PUBLICATION NO. 500001084
ISSUE 'L'
AUGUST 2010

CONTENTS

	PAGE
1.0 INTRODUCTION	1
2.0 TECHNICAL DATA	1
3.0 GENERAL REQUIREMENTS	1
3.1 Related Documents	
4.0 LOCATION	2
5.0 WATER CIRCULATION GENERAL	2
6.0 ELECTRICAL SUPPLY	2
7.0 INSTALLATION	3
7.1 General	
7.2 Water Connections	
7.2.1 Coil Connection (series flow) kit	
7.2.2 Vented applications	
7.2.3 Unvented applications	
7.2.3.1 Unvented controls	
7.3 Control box installation	
7.4 Installation of optional kits	
8.0 COMMISSIONING AND TESTING	4
9.0 SERVICING AND SPARES	5
FIGURES	
1.2 Technical Data	8
1.3 Single Coil Input Graphs.....	9
1.4 Single Coil Input Graphs - Cont'd.....	10
1.5 Dual Coil Input Graphs.....	11
2.1 General Layout and Dimensional Data.....	12
5.1 Hot Water Applications: Vented Systems.....	13
5.2 Hot Water Applications: Unvented Systems	14
5.3 Hot Water Applications: Boosted System	12
6.1 Schematic Wiring Diagram of the Control Box	12
6.2 Typical Wiring of a Powerstock Calorifier to a Boiler.....	13
6.3 Typical Immersion Heater Control System For A Powerstock Calorifier	14
6.4 Contactor Current Rating For Immersion Heaters On Single Phase & 3 Phase Supplies.....	15
6.5 Wiring Schematic for Switching A Primary Heating Coil Pump	15
7.1 Levelling Feet Assembly	16
7.2.1 Coil Connection (series flow) Kit	16
7.2.3 Unvented Applications	17
7.3 Control Box Layout	18
7.4 Earth Tag Assembly	19
9.2 Clean Out Door Flange Type	19
10.1 Top to Bottom Circulation	20

1.0 INTRODUCTION

1.1 The Powerstock range of vessels consists of seven hot water calorifier models of 160, 200, 300, 400, 500, 750 and 1000 litres volume.

1.2 The Powerstock range of vessel are WRAS approved & based on a glass lined tank enclosed within a thermally insulated outer jacket integral with the tank. The insulation jackets of the 750l & 1000l Calorifiers are however supplied separately. The calorifier is fitted with a high efficiency steel heat exchanger coil through which the primary water flows. The 160 and 200 liter models have a single primary heat exchanger coil whilst the 300, 400, 500, 750 and 1000 liter models are fitted with two primary coils which can be connected for either series or parallel operation.

Domestic drinking water is supplied from the mains to the bottom of the calorifier vessel and hot water is discharged at the top. All internal surfaces in contact with the domestic water are coated with a hygienic vitreous enamel coating, which ensures that water quality is not impaired, and is protected, by either a sacrificial or impressed current anode. For overall layout and outline dimensions refer to Figure No 1.2: Technical data.

1.3 The heat exchanger coil is designed to withstand a internal working pressure of 10 bar g. However, with suitable equipment fitted it can be used on sealed boiler systems up to 110°C primary temperature. On the secondary side drinking water can be stored up to a pressure of 6.5 bar at a maximum water temperature of 70°C. Refer to Figure No 1.2: Technical data.

2.0 TECHNICAL DATA

2.1 Overall dimensions are shown in Figure No 2.1: General layout and dimensional data.

2.2 Figure No 1.2: Technical data, shows secondary output data based on the nominated primary flow-rates at 80°C into the Powerstock unit with a secondary cold feed of 10°C and hot secondary discharge of 60°C.

2.3 The Powerstock calorifier can provide an instant volume far higher than its continuous output. This is generally shown as the 10 minute peak output, see Figure No 1.2: Technical data. Example: A PS 160 has a continuous output of 501 litres/h but can also supply an instantaneous output of 250 litres over a 10 minute period (assuming a full calorifier at the required temperature prior to flow being taken). This is equivalent to an output of 1500 litres/hour.

2.4 In order to establish an approximation of the boiler output power required for a Powerstock application the following is a simple formula;

$$\text{Powerstock output} \quad \text{kW} = \frac{V \times (T2 - T1) \times 4.185}{3600}$$

For example

Where V	=	Continuous hourly output (litres or Kg).
T2	=	Secondary water outflow temp °C.
T1	=	Cold Feed temp °C.
4.185	=	Specific heat of water kJ/kg/°C

$$\begin{aligned} \text{A PS 160 Calorifier} \quad \text{kW} &= \frac{501 \times (60-10) \times 4.185}{3600} \\ &= 29.2 \text{ kW} \end{aligned}$$

NOTE! This is the calculated Powerstock output power.

To determine the necessary boiler power required for a Powerstock application, the output power should be increased by 10% to take account of any system losses, i.e. boiler power = 1.1 x 29.2 = 32.1kW.

If a central boiler house, which also provides space heating, heats the calorifier, the actual additional loading required could be less than that calculated above. This is due to the general space heating load requirements not normally being continuously rated.

3.0 GENERAL REQUIREMENTS

The installation of the calorifier must be in accordance to the relevant requirements of the Building Regulations, Building Standards (Scotland) Regulations, **IEE Regulations** Fire regulations and Water Supply (Water Fittings) regulations.

3.1 RELATED DOCUMENTS

It is strongly recommended that the installation conforms to **BS6700:- The Design, Installation, Testing and Maintenance of Services supplying water for domestic use within buildings and their curtilages.**

Other important related documents:

Electrical Standards:- BS 3456 Part 201, EN 60335 Part 1, prEN 50165.

CP 342 Centralised hot water supply

Part 2: Buildings other than individual dwellings.

The Control of Legionella in Health Care Premises
- Code of Practice:1988 Publication HS(G) 70.

When installing this equipment, due regard must be given to the maximum working pressures and temperatures as given in Figure No 1.2: Technical data. Under **NO** circumstances must these values be

4.0 LOCATION

4.1 Refer to Figure No 2.1: General layout and dimensional data, for overall dimensions, weights and clearances required.

The location chosen must provide adequate space for servicing and inspection as required.

The calorifier must be installed on a level surface capable of adequately supporting its weight (when filled with water) and any ancillary equipment fitted.

The insulation jacket's surface must not be subjected to direct heat or radiation and must be protected from contact with boiler flues, etc.

5.0 WATER CIRCULATION GENERAL

5.1 Refer to Section 3.1 **RELATED DOCUMENTS** for detailed advice on water circuit installation.

Points of use mixing valves are recommended at each outlet to ensure high water temperatures are not discharged.

All circulation pipework must be lagged to prevent heat loss and possible freezing, especially where pipes run through roof spaces and ventilated cavities. Tanks situated in areas that may be exposed to freezing conditions should also be insulated.

Drain valves must be located in accessible positions to permit the draining of the **complete** secondary water storage system and pipework. Directly after installation, the complete system **must** be flushed through with a suitable disinfectant to thoroughly clean all materials in contact with the water. The calorifier should be flushed through several times to ensure removal of the disinfectant.

For schematic details of typical Domestic hot water systems see Figure No's 5.1, 5.2 and 5.3.

6.0 ELECTRICAL SUPPLY

6.1 WARNING: THIS APPLIANCE MUST BE EARTHED.

All wiring must be installed to comply with the relevant IEE Regulations. It must also be installed and checked by a suitably competent person.

Normal supply required is 230 volts 50Hz single phase - fused at 2 amps. A temperature limiter and thermostat are fitted inside the control box for temperature control purposes. Any voltage up to 230 volts AC can be used with external control systems. See Figure No's 6.1 and 6.2.

NOTE! If the unit is controlled from a Purewell or other boiler with remote start/stop control, it is imperative that the wiring of the Powerstock control box is of the volt free configuration. It is advisable to utilize an external relay to control this type of boiler. See Figure No 6.2: Typical wiring of a Powerstock calorifier to a boiler.

If a top to bottom circulator or powered anode is specified, these can be wired back to the Powerstock control box. See Figure No 6.2: Typical

wiring of a Powerstock calorifier to a boiler.

The sacrificial/powered anode must be connected to a suitable earthing point via a suitable earthing strap. It should not be assumed that a reliable earth path is available through the water connections. The Hamworthy powered anode kit is provided with an earth crimp, refer to Figure No 7.4: Earth tag assembly.

All wiring to the calorifier should be completed in heat resistant 1 mm². 3 core cable.

For powered anode applications it is necessary to provide a permanent power supply that is uninterrupted by time clocks etc in order to provide continuous protection.

7.0 INSTALLATION

7.1 GENERAL. For typical Domestic hot water installation schematic diagrams see Figure No's. 5.1, 5.2, and 5.3.

Overall dimension and connection details are shown in Figure No 2.1: General layout and dimensional data.

The installation should conform to the recommendations given in **BS6700** and any other relevant codes of practice.

The calorifier must be installed on a level concrete floor or plinth which is sufficient to support its weight when filled with water. See Figure No 1.2: Technical data. For minor floor irregularities three leveling feet are supplied (contained in a bag attached to the cold feed inlet) which can be screwed directly into the support plates at the base of the vessel. See Figure No 7.1: Leveling feet assembly.

Note the vessel should be mounted on the adjustable feet or a suitable plinth to ensure that there will be sufficient elevation of the cold water feed pipe to allow for wrench clearance when connecting fittings.

7.2 WATER CONNECTIONS Refer to Figure No 2.1: General layout and dimensional data.

7.2.1 COIL CONNECTION (SERIES FLOW) KIT

The 300, 400, 500, 750 & 1000 litre vessels are fitted with two independent coils that can be connected either in series or parallel to increase output performance of the vessel over that of the single coil.

A series flow kit is provided with each vessel to enable the connection of the two coils, refer to Figure No 7.2.1:Coil connection (series flow) kit.

7.2.2 VENTED APPLICATIONS Refer to Figure No 5.1: Hot water applications. The tank and water supply from it must be sized to ensure that the make-up water flow is equivalent to, or exceeds, the maximum draw off rate of the calorifier and any

other system requirements.

The hot water flow pipe from the calorifier must be fitted with an open vent connection. The vent should be sized as follows and rise to discharge over the feed tank.

PS160 & 200 > Ø19mm clear bore.

PS 300 to 500 > Ø26mm clear bore.

PS 750 to 1000 > Ø32mm clear bore.

The vent pipe shall be protected against freezing where this might occur.

No isolating valves should be fitted between the calorifier hot water outlet and the connection point of the vent.

The maximum hot working head of the Powerstock calorifier is 10 bar g. (102 metres).

Dead legs to water draw off points should be as short as possible and in no case should they exceed the lengths laid down in the water regulations guide.

For example:

- (i) Pipes < 19mm I/D Maximum dead leg = 12m
- (ii) Pipes 19-24mm I/D Maximum dead leg = 7.6m
- (iii) Pipes > 25mm I/D Maximum dead leg = 3m

7.2.3 UN-VENTED APPLICATIONS Refer to Figure No 5.2. & 5.3. Any un-vented installation must follow the essential safety requirements of the **Buildings Regulations part G3 Section 2**. This document further states that the system should be designed by appropriately qualified engineers and fitted by approved installers.

The cold feed un-vented kit(s) offered by Hamworthy Heating comprise a valve train assembly incorporating expansion relief valve, non-return valve, strainer and pressure reducing valve plus a suitably sized expansion vessel compatible with potable water and sized for the unit and local pipework. A temperature/pressure relief valve is also supplied which follows the sizing recommendations from the valve supplier. This ensures adequate protection even with low incoming water mains pressures.

Refer to Figure No 7.2.3: Unvented applications for details and descriptions of kit contents.

For comprehensive recommendations on the design, installation and testing of water supply services, attention is drawn to the appropriate sections of **BS 6700**.

The maximum hot working head of the Powerstock calorifier is 10 bar g. (102 metres).

Dead legs to water draw off points should be as short as possible and in no case should they exceed the lengths laid down in the water regulations guide.

- (i) Pipes < 19mm I/D Maximum dead leg = 12m
- (ii) Pipes 19-24mm I/D Maximum dead leg = 7.6m
- (iii) Pipes > 25mm I/D Maximum dead leg = 3m

7.2.3.1. UNVENTED CONTROLS.

7.2.3.1.1 SECONDARY HOT WATER SIDE. The pressure temperature relief valve must be fitted directly into the vessel at the location indicated in Figure No 2.1.

Remove the ABS top cover from the vessel exposing the top connection point. Remove the 1" BSP brass plug and screw the P & T, relief valve into this position using a suitable WRAS approved jointing compound.

Cut a 130mm-diameter hole in the centre of the ABS top cover to clear the P & T, relief valve then refit the cover to the vessel. The installation of pipework from the P & T, relief valve outlet should conform to the recommendations given in **BS6700** and any other relevant codes of practice.

7.2.3.1.2 COLD WATER FEED SIDE. For typical installation applications refer to Figures No's 5.2 and 5.3. The Hamworthy Heating valve train is sized to provide flow rates of approximately 4800 l/h under the assumed conditions of 2 bar incoming mains water pressure and 1 bar static back pressure resulting from the highest distribution lines above the vessel and flow resistances of the system.

Potential flows will increase with higher mains pressures up to the 3.5 bar preset regulator pressure. However due to the many variables involved it is recommended that the flow rate of 4800 l/h is considered the maximum.

An expansion vessel that is pre-charged at 3.5 bar and sized to accept the water expansion volume from a Powerstock and its local associated pipework is supplied with each un-vented Powerstock.

If the water train is serving a large distribution system additional expansion vessels maybe required and the acceptance volume V2 can be calculated as follows:

$$V2 = \frac{e_t \times V1}{1 - \left(\frac{P_c}{P_w} \right)}$$

Where e_t is the expansion factor which for a 65°C rise = 0.02.

V1 is the volume of the entire system including the heater.

Pc is the absolute expansion vessel cushion pressure normally preset to 4.5 bar. Absolute = (3.5 bar gauge + 1 bar.)

Pw is the absolute working pressure and is the same value as that of the expansion relief valve setting 6 bar. Absolute = (5 bar gauge + 1 bar.)

V2 is the volume of the required expansion vessel.

7.3 CONTROL BOX INSTALLATION. Refer to Figure No. 7.3 Control box layout.

Remove the control box from its cardboard box and remove the control box cover by first pulling off the thermostat knob and unscrewing the four screws (two top, two bottom). The control box mounting boss and fittings are located in a polythene bag inside the control box housing.

1) For PS160 to PS500 assembly, locate the control box-mounting boss over the thermostat-mounting pocket so that the lip of the boss engages into the groove of the thermostat pocket.

(Note: it maybe necessary to cut away a small amount of the insulation to enable the fitment of the boss.)

Tighten the set-screw to lock the boss onto the thermostat pocket ensuring that the two M5 threaded holes are aligned to the horizontal plane.

Fit the control box back plate onto the mounting boss using the two M5 studs. Thread the control thermostat and temperature limiter bulbs into the thermostat pocket ensuring that the w-shaped spring clip retains the bulbs in a secure and suitable position. Coil and arrange the capillaries within the control box housing. Then fit the detachable mounting plate.

2) For PS750 & PS1000 assembly, ensure the insulation jacket has been assembled to the vessel. Locate the control box over the pillars of the mounting bracket supplied and secure using two M5 screws. Assemble the bracket over the top two pipe stubs and fix the bracket using the circlips provided. Thread the control thermostat & temperature limiter bulbs into the thermostat pocket below the lower pipe stub to which the bracket is affixed. Use the w-shaped clips to secure the bulbs within the pocket.

3) For all models, complete the necessary wiring using the appropriate wiring diagram (figures 6.1 and 6.2) before fitting the control box cover.

7.4 INSTALLATION OF OPTIONAL KITS.

7.4.1 POWERED ANODE PROTECTION.

Isolate ALL electrical supplies to the control box. Isolate and drain the potable water from the vessel. Locate the magnesium sacrificial anode, (see Figure No 2.1 for anode location) unscrew and remove from the vessel. Select the new powered anode and screw it into the open tapping. The screw thread contains an integral sealing gasket but if additional sealant is used, ensure that it is WRc approved. Refill the vessel. Remove the control box cover by first pulling off the thermostat knob and unscrewing the four screws (two top, two bottom) refer to Figure No 7.3: Control box layout.

Select the potentiostat unit (grey plastic box) and locate on the two studs on the base plate with the live

and neutral terminals at the bottom. Secure with the M3 nuts and washers provided.

Select the power loom and connect the blue crimped cable to N of the potentiostat and the brown to L. Connect the other ends to the terminal rail, brown to 3 and blue to N. Select the indicator lamp and pull off the plastic grommet. Push the grommet through the small hole in the front of the thermostat mounting plate and replace the lamp in the grommet from behind. Connect the miniature plug into the top of the potentiostat. Using the pre-punched hole in the control box cover as a guide cut out the hole for the neon in the self adhesive fascia label.

(Refer to Figure No 7.4: Earth tag assembly) Clean and abrade the outer surface of the cold water feed stub pipe at the base of the vessel to obtain a suitable earthing continuity point.

Select the jubilee clip and undo the screw until the clamping band can be opened out. (Note: this action may not need to be carried out if site pipework has not yet been installed to the vessel). Place the jubilee clip over the cleaned and abraded area of the cold water feed pipe and reassemble the clamping band. Select the earth mounting crimp and fit the pierced flat spade between the stub pipe and the jubilee clip clamping band. Tighten the jubilee clip to lock the earth terminal against the stub pipe.

Select the anode connection cable and feed the cable through the control box left-hand gland from the outside, leading with the two different sized crimps. Fit these crimps to the appropriate spades on the potentiostat unit and secure the cable in the gland. Connect the other end of the cable with the crimp onto the anode spade. Remove the forked spade from the cable and replace it with the supplied crimp. Connect this cable to the earthing crimp on the cold feed stub pipe.

(Note: the earth connection must be made to the cold water feed pipe or other point on the vessel to guarantee continuity between the earth and the wall of the vessel and correct operation of the powered anode).

Replace the control box cover and the thermostat knob.

To ensure safe & efficient operation of the Powered Anode the following points need to be observed:

1) That the vessel is full of water before switching on the electrical supply. If everything is satisfactory, the lamp will glow green. The lamp will flash red as a warning if there is a problem. This indicates that the protection is not effective and one of the following has occurred.

- a) There is no water in the vessel.
- b) There is a short circuit between the anode and the vessel.
- c) The two-core cable to the anode has been connected the wrong way round.

On rectification of faults above interrupting the mains electrical supply to the unit for a brief period (30 seconds) will reset the indicator lamp.

2) Time clocks, etc must NOT interrupt power to this circuit. To enable the powered anode system to provide continuous protection it must have a permanent power supply.

3) The powered anode must be switched off if the Powerstock water heater in which it is installed is to stand longer than 2 months undrained & without any draw off of water from the vessel.

4) Do not disconnect the anode from the potentiostat by detaching the connecting cable to the anode if the storage water heater is full otherwise no protection will be provided against corrosion.

5) Before touching the impressed-current anode, the electrical supply to any immersion heater in the tank must be disconnected, as mains voltage may be present on the impressed anode should the immersion heater be defective.

Ensure periodic electrical checks of the immersion heater & impressed current anode by a specialist.

7.4.2 FLANGE KIT FOR IMMERSION ELEMENT.

(see Figure No 9.2)

A flange kit for an immersion element is available with fitting instructions.

HHL Part No. 563605221 PS160-500 Models

HHL Part No. 563605466 PS750-1000 Models

Immersion elements below are supplied optionally
4kW x 280mm long, 240V a.c. Part No. 533901393 &
9kW x 280mm long, 240Vac. Part No. 533901489.

NOTE: 1. Models PS160 and PS200 cannot have an immersion element fitted if the unit also has an unvented kit supplied.

To meet the requirement of BS6700 and BS EN 806-2, it is recommended that where an immersion element is fitted on an unvented

system, the electrical supply to the immersion element should be connected to the manual reset limit thermostat of the vessel control panel in addition to the boiler, via suitable relays/contactors (not Hamworthy Heating Ltd supply). This ensures that in the event of a high temperature condition occurring, both sources of energy will be safely shut down. See figure 6.3 for a schematic of an immersion heater wired to the control panel. See figure 6.4 for contactor current rating of the heater for single / 3 phase wiring.

7.4.3 TOP TO BOTTOM CIRCULATION.

A top to bottom circulation kit can be supplied for each calorifier. (Refer to Figure No. 10.1).

Where the internal coil of the heater is connected to a solar thermal heating system the circulation pump is only used during the daily legionella bacteria pasteurization cycle, as stratification in the tank is required. For applications where the primary coil of the vessel is connected to a boiler only the pump can be run continuously to ensure de-stratification of the calorifier contents.

The kit is supplied for assembly to the calorifier when the calorifier is located in its final position.

NOTE 1: The connection Tee's must be fitted to the hot water flow and cold water return connections prior to any connection to the system pipework.

NOTE 2: All jointing compound used should be approved suitable for potable water by WRAS.

NOTE 3: Ensure flow arrows on the pump and check valve allow flow from the top to the bottom of the Calorifier.

The pump will require connection to a 230Vac 50Hz electrical supply via a fused isolator using heat resisting 3 core cable of adequate rating (not HHL supply). Refer to pump manufacturer's instructions for details of fuse sizing etc.

WARNING: This pump must be earthed.

8.0 COMMISSIONING AND TESTING

8.1 Once all installation work has been completed the unit should be filled with water to check for leaks.

For the calorifiers do this on both primary & secondary sides.

Calorifiers should be thoroughly flushed through to remove debris from vessels / pipework, etc. Refer to section **5.0 WATER CIRCULATION GENERAL** and the relevant standard or code of practice for correct procedure. The system should be chemically cleaned with an approved disinfectant before use.

Switch on the boiler or heat source and ensure flow-rates are correct as per Figure No 1.2 Technical data.

Note! Calorifier performance is directly affected by changes in primary flows and temperatures.

Check for the correct operation of the thermostat depending on the control system used, see Figure No's 6.1 and 6.2. If controlling a diverter valve, check that when the calorifier reaches the desired set point the valve fully shuts off the calorifier and opens the by-pass loop.

This should be checked without secondary water flowing through the calorifier, thus keeping the time required for checking this operation to a minimum.

9.0 SERVICING AND SPARES

9.1 The calorifier should be regularly checked for correct operation.

The sacrificial anode must be inspected at least once every 6 months for loss of material. Refer to Hamworthy Heating for spares.

IMPORTANT: Due to the variable chemical nature of distributed water supplies, it is recommended that in addition to the annual inspection cleaning, this appliance is inspected for calcium deposition anode loss within a maximum of three months following initial commissioning and the frequency of subsequent inspections adjusted accordingly.

Failure to install in accordance with the relevant **Hamworthy Heating Installers Guides** and to carry out the above recommendations may compromise appliance warranties.

WARNING: Before proceeding with any maintenance, isolate the electrical supply to the storage tank being serviced.

NOTE: If anodes are to be inspected proceed to the next paragraph before replacing insulation and tank top.

9.2 INSPECTION OF THE STORAGE TANK WATERSIDE SURFACES AND MAGNESIUM ANODES

9.2.1 DRAINING THE STORAGE TANK

Isolate the cold feed, hot flow and circulation connections. Connect a ¾" nominal bore hose to the drain cock connection at the bottom of the storage tank, run the hose to a convenient drainage point, open the storage tank drain cock and drain the tank.

9.2.2 REMOVAL OF INSPECTION DOOR

After checking to ensure that the storage tank has been fully drained, remove the four screws retaining the exterior (blue) casing panel of the inspection door.

Remove the panel and the insulation disc to expose the inspection door flange and fixing bolts. Slacken and remove the M10 bolts and take off the inspection door.

Inspect the interior surfaces of the storage tank for any signs of calcium deposit.

Providing that exit water flow temperature has been restricted to a maximum of 60°C deposits should not normally be present. If any deposits do exist within the storage tank, these can be removed with the aid of a stiff brush and a water jet (directed through the inspection port) and flushed through the drain connection of the tank.

NOTE: On no account should a metal scraper be used to remove deposits since this may result in damage to the glass lining.

After cleaning, replace the inspection door and gasket.

9.3 INSPECTION OF MAGNESIUM ANODES

NOTE: On no account remove the magnesium anodes without checking to ensure that the storage tank is isolated on flow, feed and circulation waterside connections.

Each storage tank includes sacrificial magnesium anodes. See figures 2.2 & 2.3.

Release the nuts securing the magnesium anodes (this will require a 32mm socket spanner (PS750/1000) and 27mm (PS160/200/300/400/500) complete with extension bar) and withdraw the anodes vertically through the ¾" BSP sockets and clear of the storage tank. Remove the copper anode sealing washer and inspect each anode for erosion. If the extent of erosion is sufficient to have reduced the cross-sectional area of the anode by fifty percent i.e. the diameter of the anode is less than 15 mm, it should be replaced complete with a new sealing washer.

9.4 ASSEMBLY - FOLLOWING COMPLETE SERVICING OF THE STORAGE TANK.

Close the storage tank drain cock and remove the hose connection.

Open the cold feed, hot flow and circulation isolation valves and allow the system to fill with water.

Check to ensure that there are no leaks from the inspection door sealing gasket, the magnesium anode sealing washers and the drain cock.

Replace the insulation disc over the inspection door flange and refit the exterior casing panel with the four screws.

9.2 RECOMMENDED SPARES.

SPARES ITEM	PART No
Magnesium Anode PS160-200	539001075
Magnesium Anode PS300	539001076
Magnesium Anode PS400 & 500	539001077
Magnesium Anode PS750	539001108
Magnesium Anode PS1000	539001109
Insulation Jacket PS750	533806070
Insulation Jacket PS1000	533806071
Insulation Jacket ST750	533806077
Insulation Jacket ST1000	533806078
Thermometer (gauge)	557002006
Clean out door gasket (PS160 to PS500)	531201041 Refer to Fig No 9.2
Clean out door gasket (PS750, PS1000)	531201148 Refer to Fig No 9.2
Potentiostat	533901345
Indicator lamp	533901346
Control thermostat	533901178
Temperature limiter	533901343
Fuse 2A	747225834

Figure 1.2. Technical data.

Calorifier Model	PS160	PS200	PS300	PS400	PS500	PS750	PS1000
General data.							
Storage Capacity (litres)	160	200	292	380	470	750	995
Top Coil Surface Area (sq. metres)	N/A	N/A	0.80	1.05	1.30	1.17	1.12
Bottom Coil Surface Area (sq. metres)	0.75	0.95	1.55	1.80	1.90	1.93	2.45
Max Operating Pressure (Primary) (bar)	10						
Max Operating Pressure (Secondary) (bar)	10						
Max Operating Temp (°C)	Primary = 110°C Stored water = 70°C						
Weight Empty (kg)	70	80	130	185	215	217	275
Weight Full (kg)	230	280	422	565	685	967	1270
Operational data: Bottom coil only in operation.							
Primary Temperature (°C)	80						
Stored water temperature (°C)	60						
Continuous Output (l/h) Secondary out = 60°C, Cold feed = 10°C	501	600	816	976	1109	1062	1281
Heat input (kW)	29.2	35.6	48.4	57.9	65.7	63	76
10min Peak Output (litres)	250	362	448	615	771	1100	1197
Recovery time 10-60°C (minutes)	20	20	22	24	26	42	46
Operational data: Top and bottom coils connected for series operation.							
Primary Temperature (°C)	80						
Stored water temperature (°C)	60						
Continuous Output (l/h) Secondary out = 60°C, Cold feed = 10°C	N/A	N/A	1032	1285	1549	1432	1635
Heat input (kW)	N/A	N/A	61.2	76.2	91.8	85	97
10min Peak Output (litres)	N/A	N/A	567	889	1077	1319	1483
Recovery time 10-60°C (minutes)	N/A	N/A	17	18	18	31	36

Example use of graphs

Assume a PS160 is required to operate on a boiler plant with flow and return temperatures of 80/70°C. Required temperature drop through primary coil = 80 - 70 = 10°C. From Graph the required flow rate will be 0.71/s which generates a pressure drop of 60mbar.

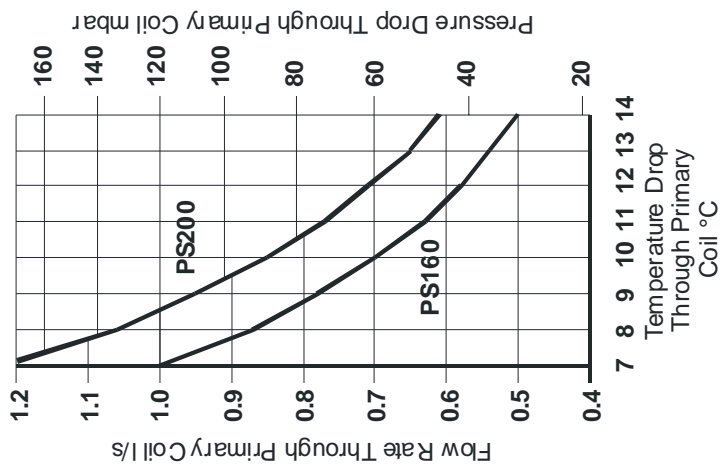

PS160 - 200 single coil

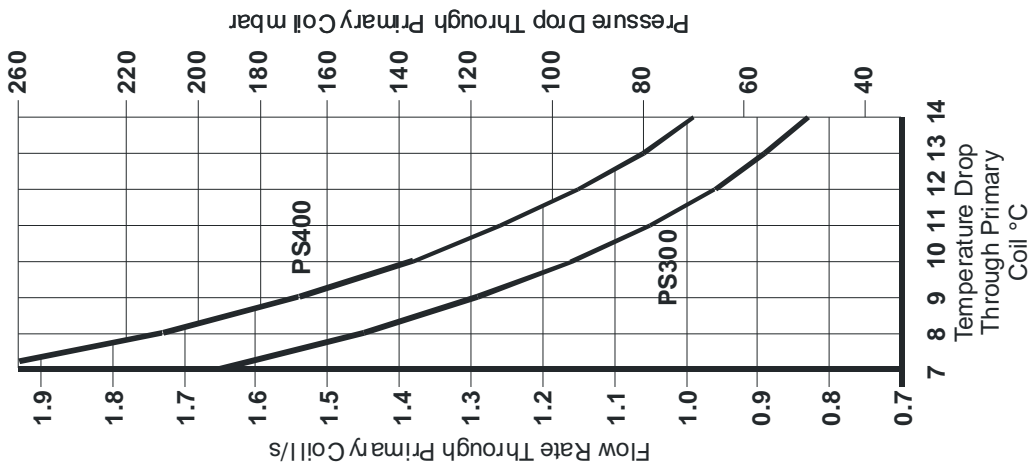

PS300 - 400 single coil

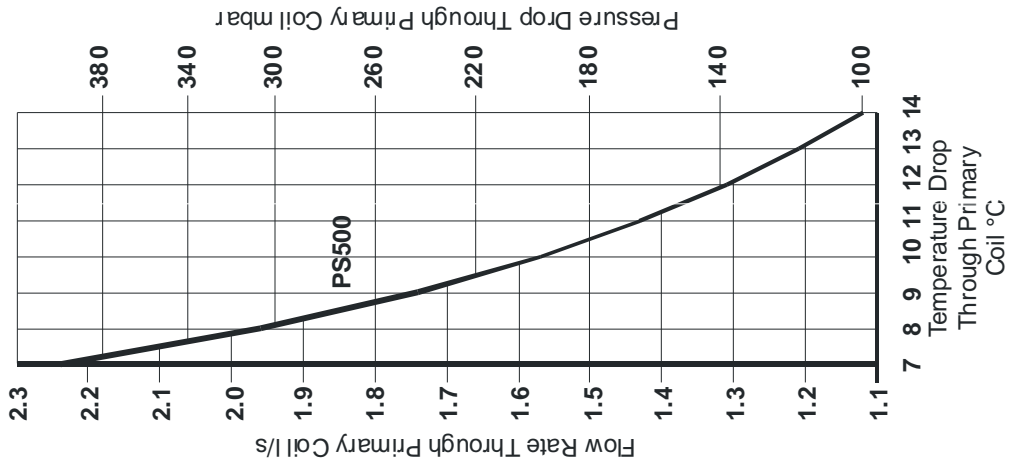

PS500 single coil

Figure 1.3 Single coil input graphs

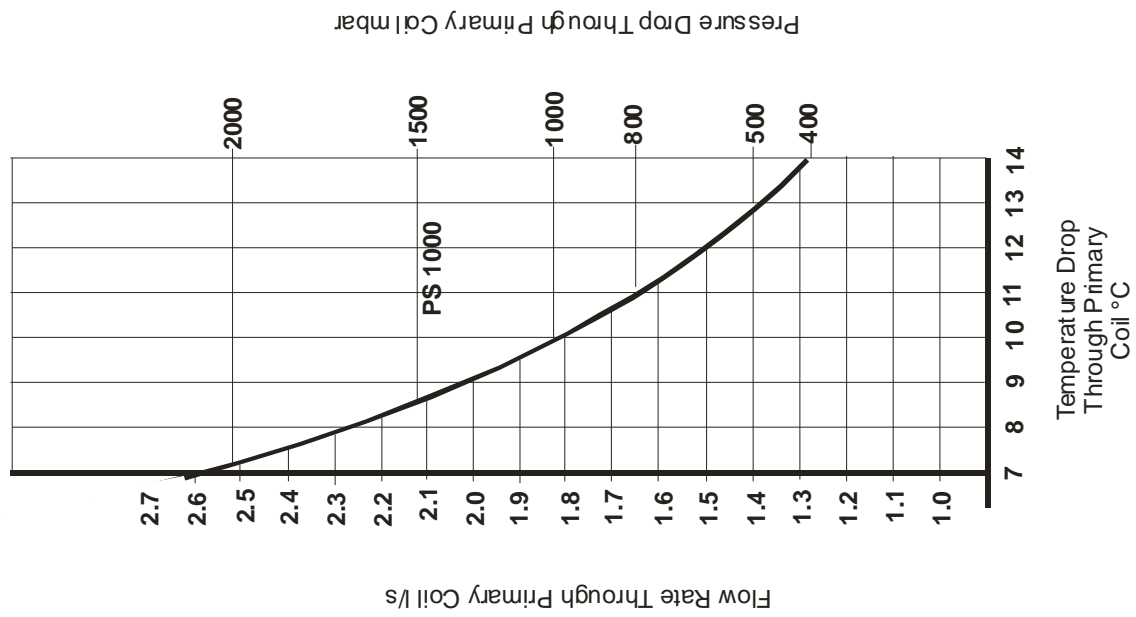

PS 1000 single coil

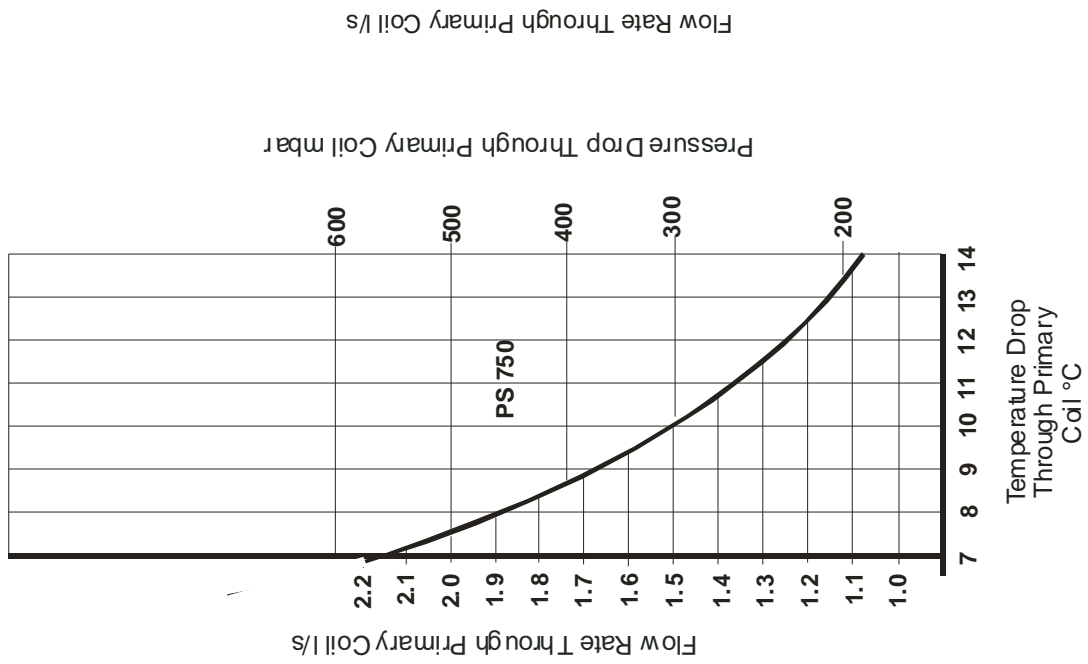

PS 750 single coil

Figure 1.4 Single coil input graphs - Cont'd

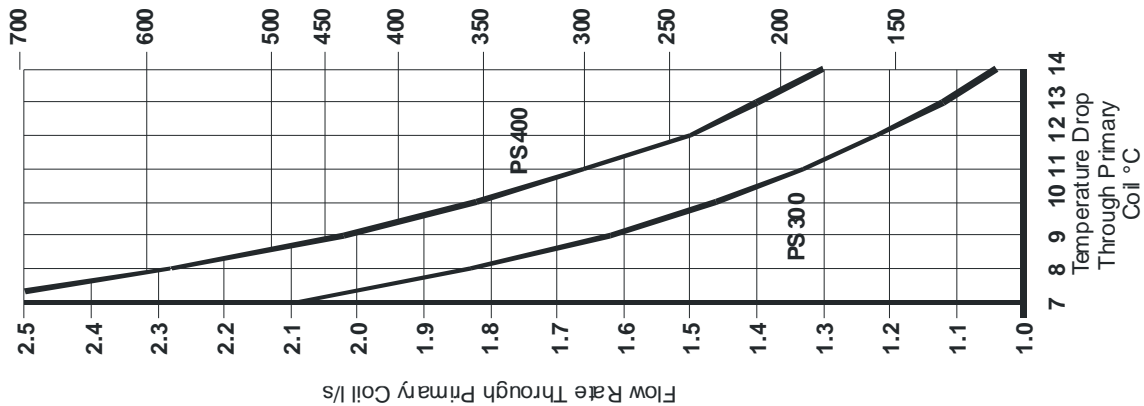

PS300 - 400 dual coil

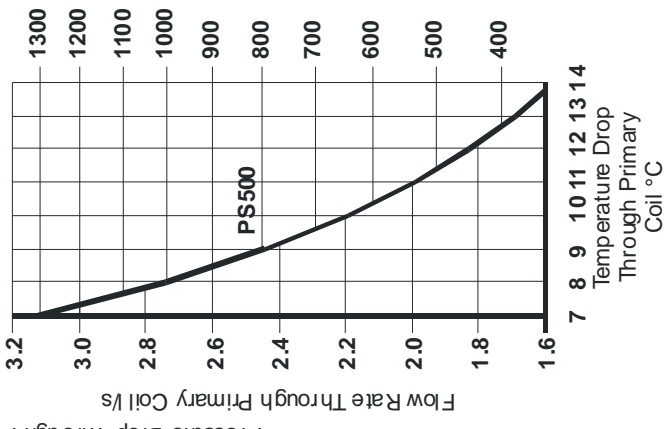

PS500 dual coil

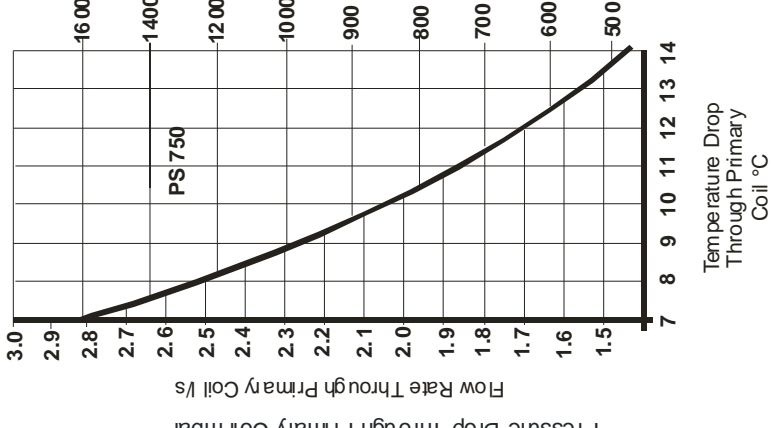

PS750 - dual coil

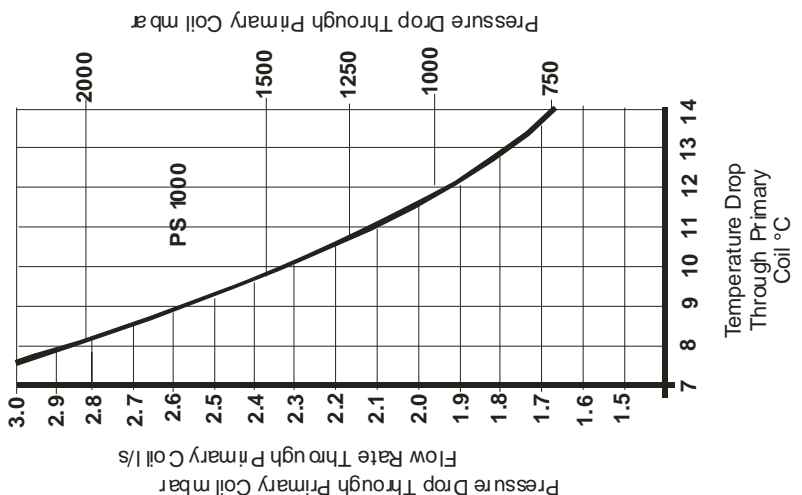

PS1000 - dual coil

Figure 1.5 Dual coil input graphs

NOTE: FOR UNVENTED APPLICATIONS THE SAFETY RELIEF VALVE ON ALL POWERSTOCK VESSELS MUST BE FITTED AT THIS LOCATION.

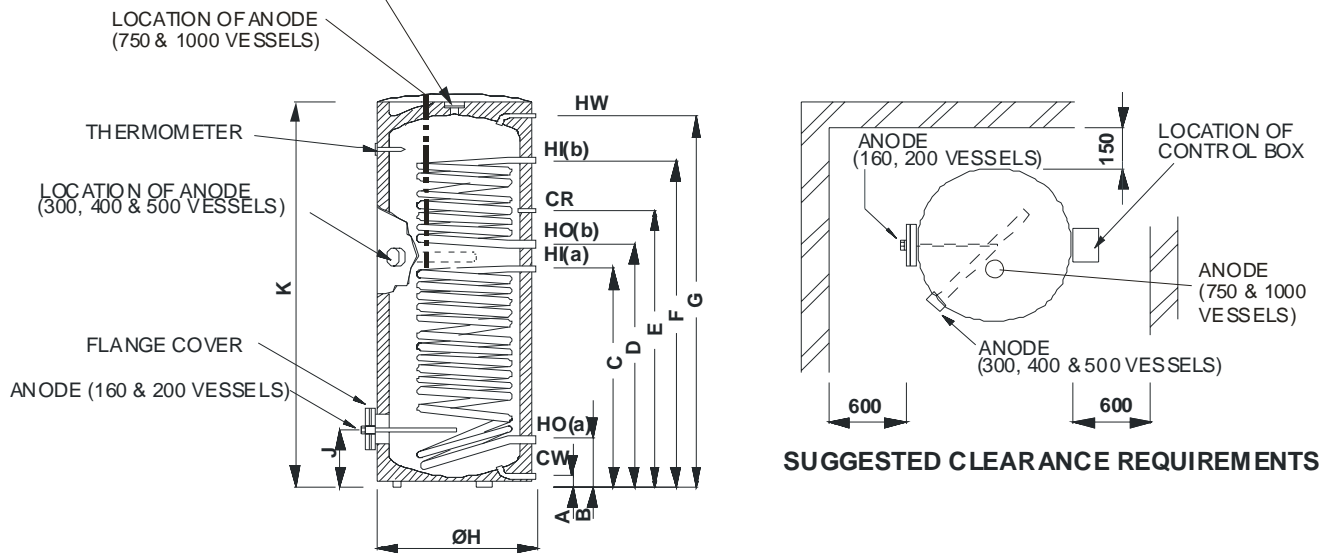

MODEL		PS160	PS200	PS300	PS400	PS500	PS750	PS1000
DIMENSIONS (mm)	A	55	55	90	55	55	103	103
	B	191	191	254	220	220	288	296
	C	596	686	964	909	965	830	884
	D	N/A	N/A	1064	1006	1114	1151	1153
	E	732	899	1179	1111	1264	1242	1243
	F	N/A	N/A	1424	1354	1604	1467	1423
	G	1106	1366	1725	1523	1853	1887	1905
	H	540	540	625	700	700	910	1010
	J	246	246	324	275	275	378	386
K	1172	1432	1775	1591	1921	1998	2025	
CONNECTIONS	HW Hot water outlet.	R ¾"	R ¾"	R 1"	R 1"	R 1"	R 1¼"	R 1¼"
	HO(b) Upper primary coil outlet.	N/A	N/A	R 1"	R 1"	R 1"	R 1"	R 1"
	CR Circulation return.	R ¾"	R ¾"	R ¾"	R ¾"	R ¾"	R ¾"	R ¾"
	HI(b) Upper primary coil inlet.	N/A	N/A	R 1"	R 1"	R 1"	R 1"	R 1"
	HO(a) Lower primary coil outlet.	R 1"	R 1"	R 1"	R 1"	R 1"	R 1"	R 1"
	HI(a) Lower primary coil inlet.	R 1"	R 1"	R 1"	R 1"	R 1"	R 1"	R 1"
CW Cold water feed.	R ¾"	R ¾"	R 1"	R 1"	R 1"	R 1¼"	R 1¼"	

Figure 2.1 General layout and dimensional data.

Item Number	Document Number	Title	Quantity
1	563906289	PS160 Calorifier Vessel	1
2	563902185	Control Panel	1
3	563605504	PS160 PTRV Kit	1
4	563605529	PTRV Discharge Pipework Kit	1
5	563906289	PS160 Calorifier Top	1
6	563906387	Re-circulation Pump Kit	1
7	532104003	Bulb Retention Spring	2
8	531201041	Calorifier Flange Gasket	1
9	563906290	Calorifier Cleanout Flange	1
10	741627482	1 1/2" To 1 1/4" Hex Bush	1
11	563906300	Rp1 1/4" Magnesium Anode	1
12	563906290	Flange Cover	1
B	748214340	M10 x 25 Hex HD Screw	8

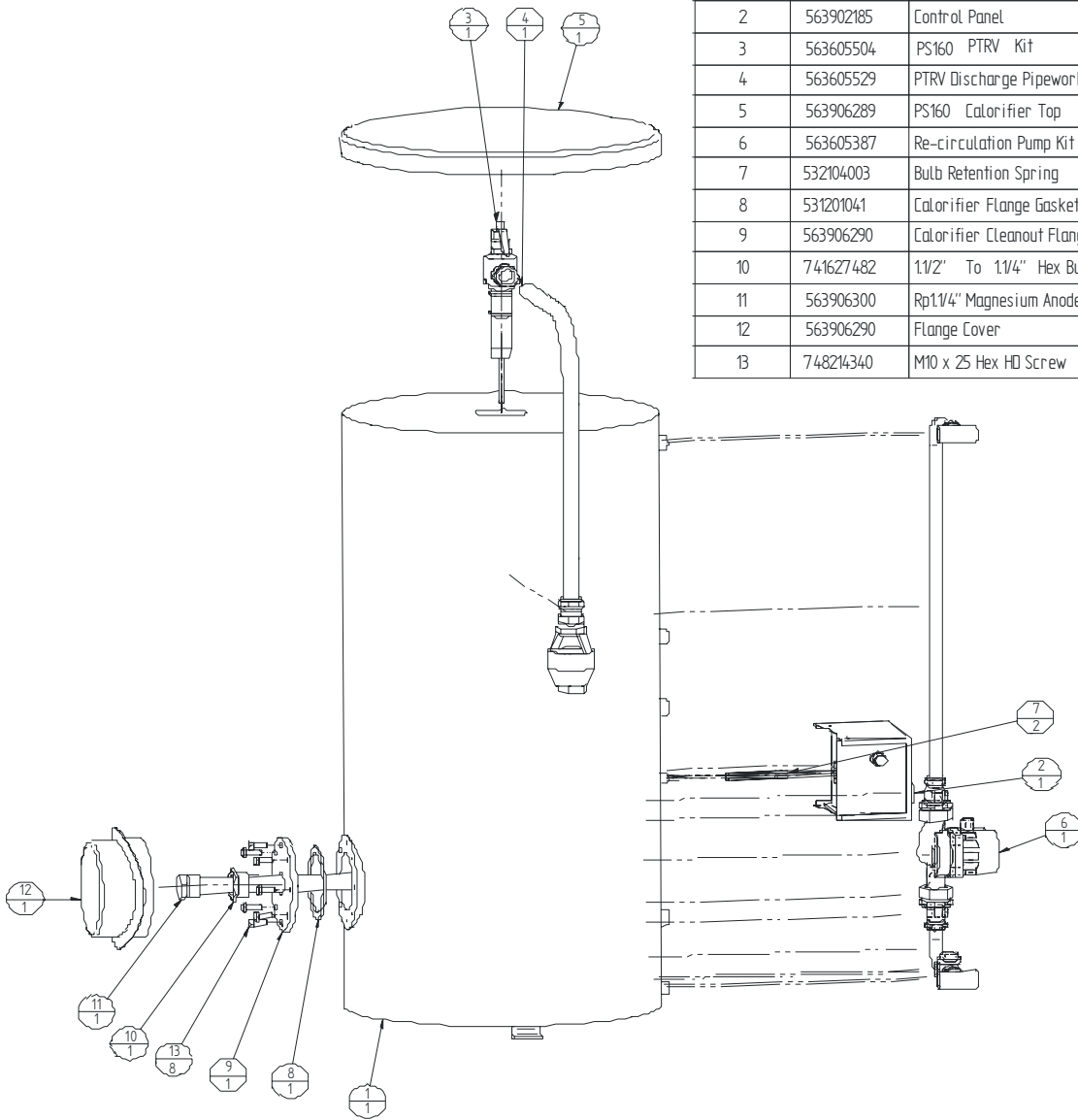

Figure 11.0 PS160 Assembly.

Item Number	Document Number	Title	Quantity
1	563906290	PS200 Calorifier Vessel	1
2	563906290	Calorifier Top	1
3	563902185	Control Panel	1
4	563605504	Pressure Temperature Relief Valve	1
5	563605530	Optional Outlet Pipework PTRV Kit	1
6	563605388	Re-circulation Pump Kit	1
7	532104003	Bulb Retention Spring	2
8	563906290	Calorifier Flange	1
9	741627332	1 1/2" To 1/4" Hex Bush	1
10	563906290	Rpt 1/4" Magnesium Anode	1
11	563906290	Flange Cover	1
12	531201041	Calorifier Flange Gasket	1
13	748214340	M10 x 25 Hex HD Screw	8

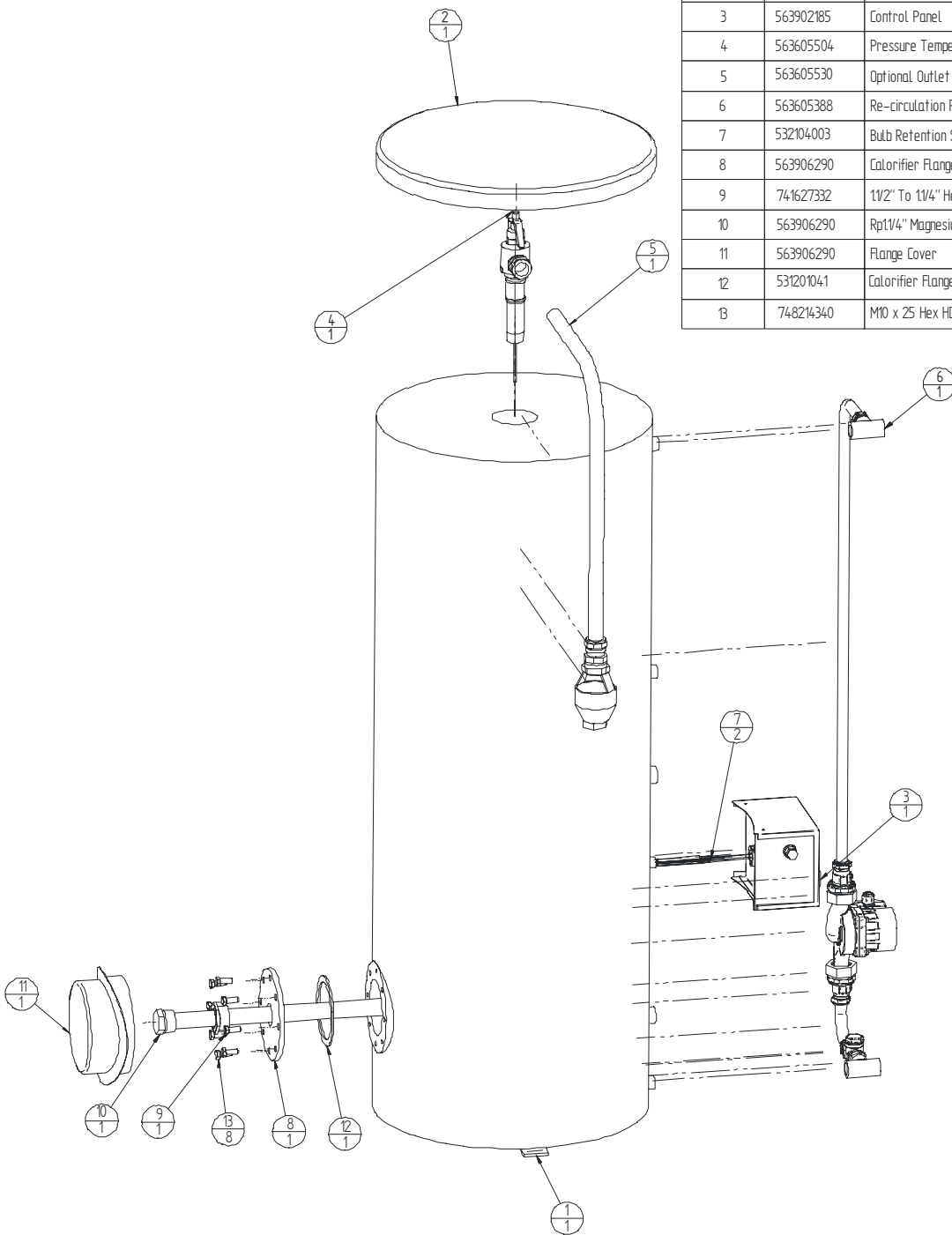
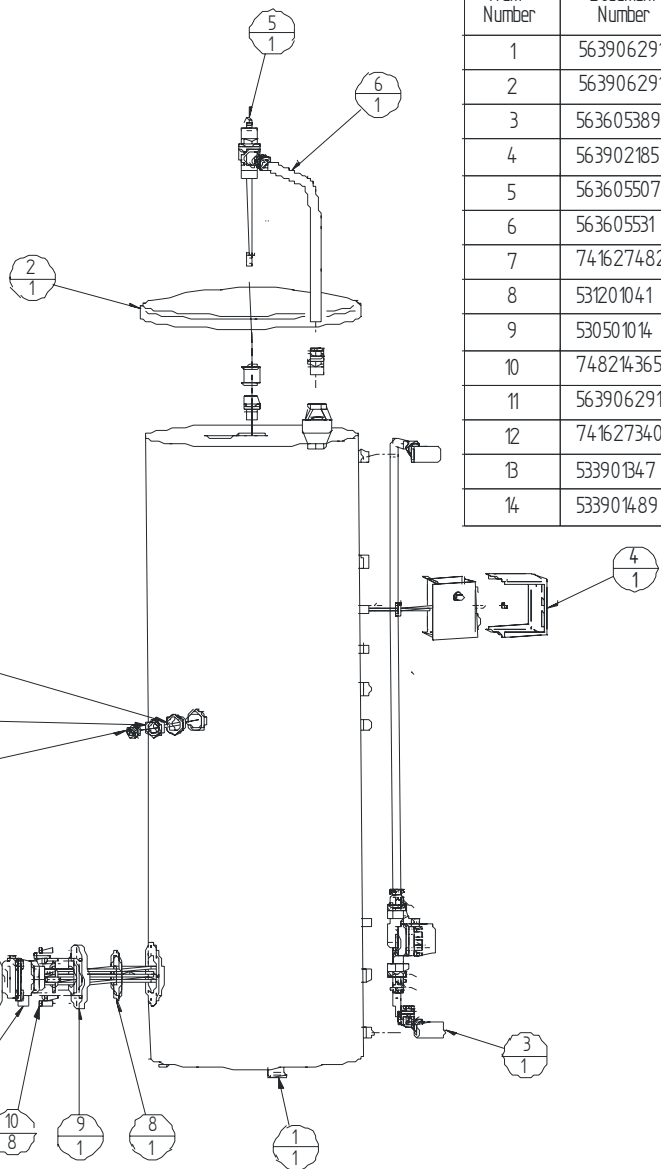

Figure 12.0 PS200 Assembly.



Item Number	Document Number	Title	Quantity
1	563906291	Calorifier Vessel	1
2	563906291	Calorifier Top	1
3	563605389	Recirculation Pump Kit	1
4	563902185	Control Panel	1
5	563605507	PTRV Kit	1
6	563605531	Optional Discharge Pipework Kit	1
7	741627482	1 1/2" To 1 1/4" Hex Bush	1
8	531201041	Calorifier Flange Gasket	1
9	530501014	Flange Adaptor For Immersion Element	1
10	748214365	Hexagon Head Screw ISO4017 - M10x35	8
11	563906291	Flange Cover	1
12	741627340	Hex. Bush Male R 1 1/4" x Female Rct"	1
13	533901347	Impressed Current Electrode	1
14	533901489	9kw Immersion Element	1

Figure 13.0 PS300 Assembly With Impressed Current Anode & Immersion Heater.

Item	Document Number	Title	Quantity
1	563906292	PS400 Calorifier Vessel	1
2	563906292	PS400 Calorifier Top	1
3	563905508	Pressure Temperature Relief Valve Kit	1
4	563902185	Control Panel	1
5	741627332	1.1/2" TO 1.1/4" BSPT Hex Bush	1
6	563906292	1" BSPT Bronze Plug	1
7	563605533	Discharge Pipe Kit	1
8	563605390	Re-circulation pump kit	1
9	563605174	Series Flow Coupling Kit	1
10	532104003	Bulb Retention Spring	2
11	531201041	Cleanout Flange Gasket	1
12	563906292	Cleanout Flange	1
13	748214340	M10x25 Hex HD Screw	8
14	563906292	Flange Cover	1
15	563906292	1.1/4" BSPP Magnesium Anode	1
16	557002006	Thermometer	1

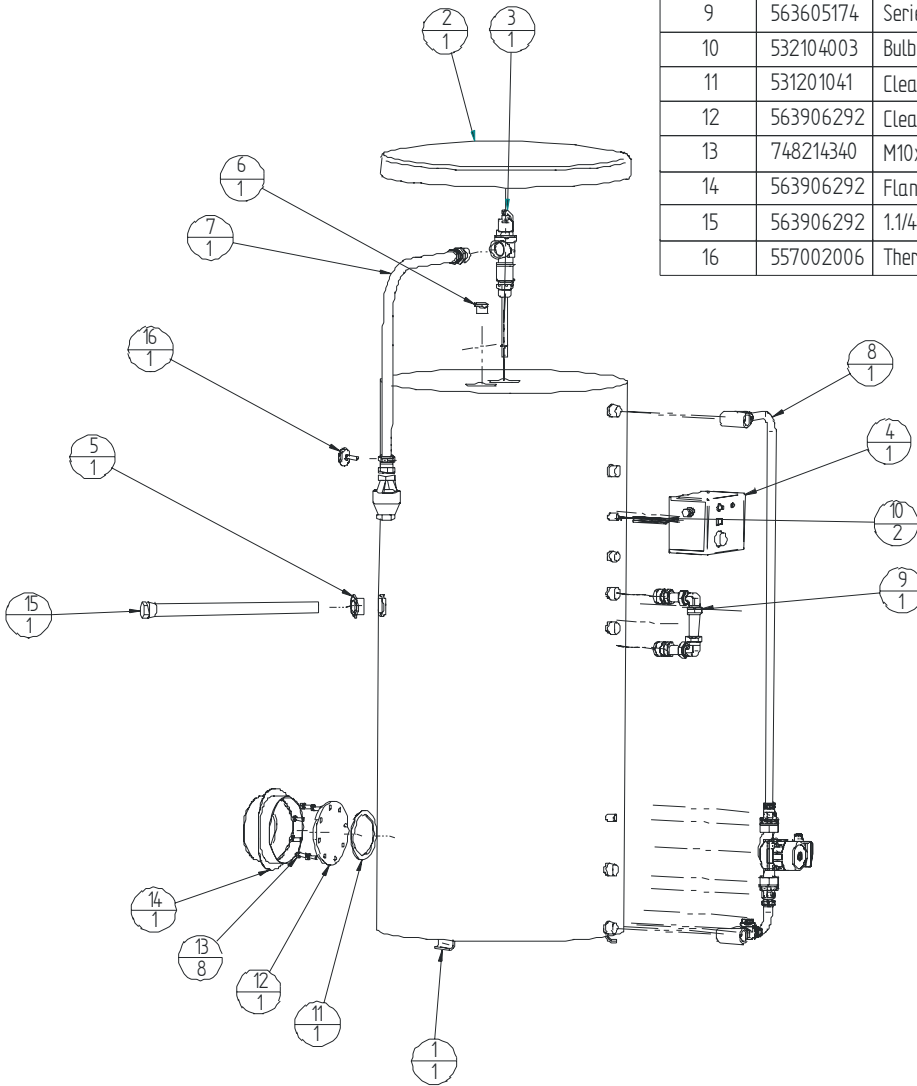

Figure 14.0 PS400 Assembly.

Item Number	Document Number	Title	Quantity
17	744627332	1 1/2" To 1 1/4" Hex Bush	1
18	531201041	Calorifier Flange Gasket	1
19	530501014	Flange Cover	1
20	748214365	M10x35 Hex H.D. Screw ISO 4017	8
21	563906291	Flange Cover	1
22	744627340	1 1/4" x 1" Hex Bush	1
23	533901347	Impressed Current Anode	1
24	533901489	9kW Immersion Element	1

Item Number	Document Number	Title	Quantity
1	563906293	PS500 Calorifier Vessel	1
2	563906293	PS500 Calorifier Top	1
3	563605508	Pressure Temperature Relief Valve	1
4	557002006	Thermometer	1
5	563902185	Control Panel	1
6	744627332	1 1/2" To 1 1/4" Hex Bush	1
7	563906293	R1" Brass Plug	1
8	563605533	Discharge Pipe Kit	1
9	563605391	Re-circulation Pump Kit	1
10	563605174	Series Flow Coupling Kit	1
11	532104003	Bulb Retention Spring	2
12	531201041	Cleanout Flange Gasket	1
13	563906293	Cleanout Flange	1
14	748214340	M10x25 Hex H.D. Screw	8
15	563906293	Flange Cover	1
16	563906300	Rpt 1/4 Magnesium Anode	1

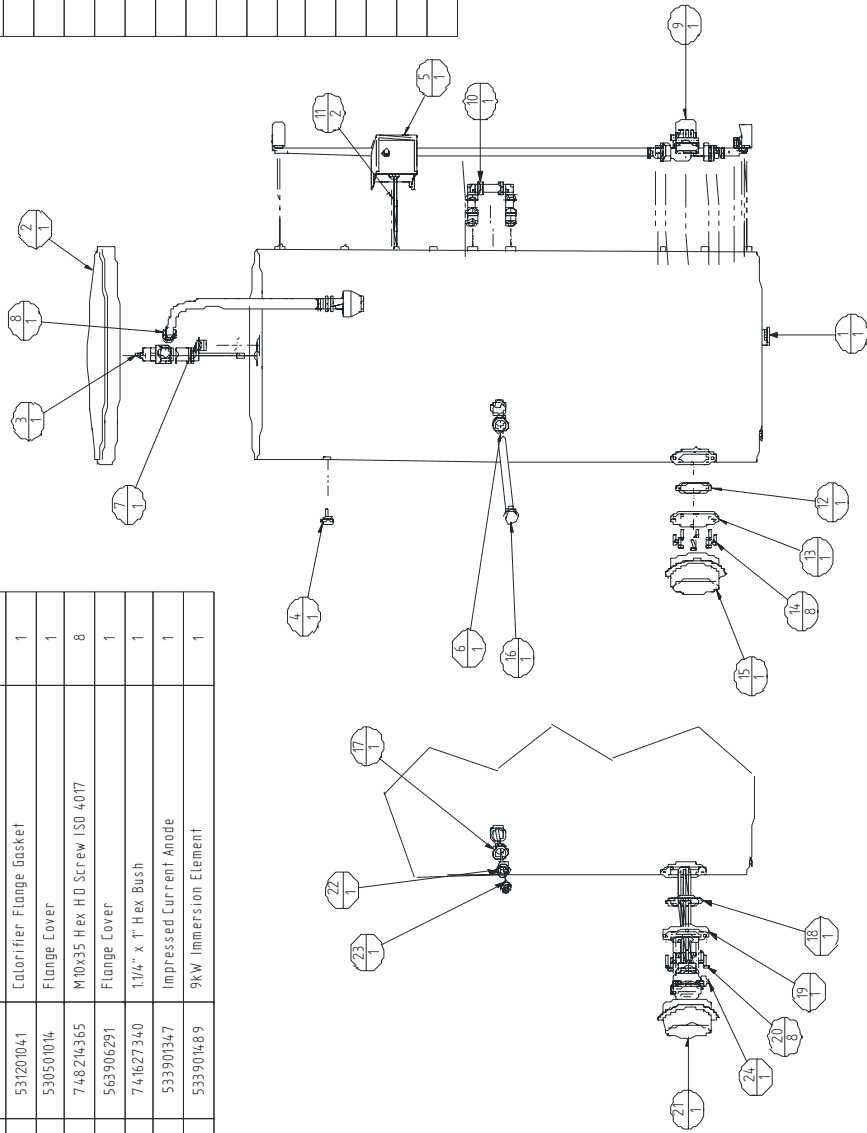
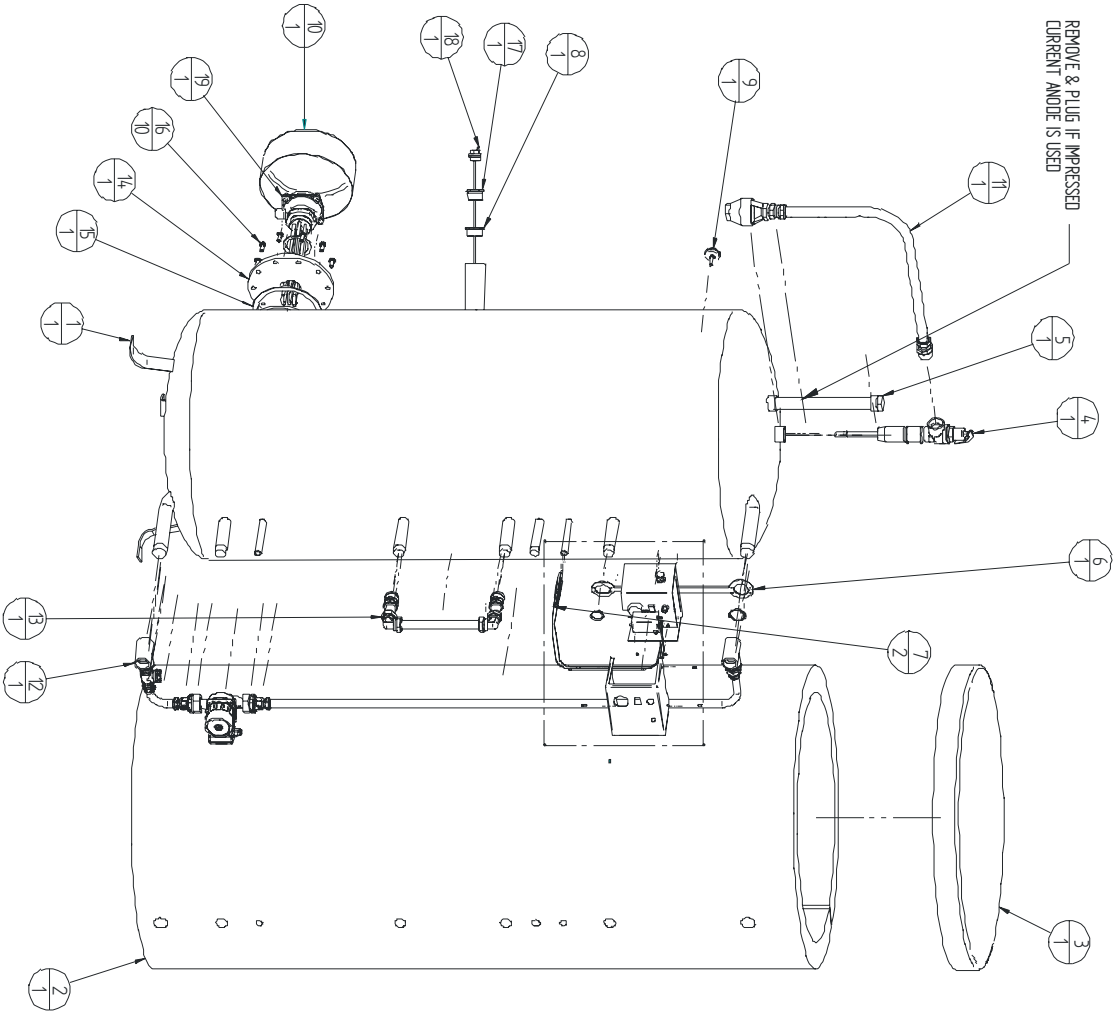

Figure 15.0 PS500 Assembly.



Item Number	Document Number	Title	Quantity
1	563906294	PS750 Calorifier Vessel	1
2	533806070	PS750 Calorifier Jacket	1
3	533806070	PS750 Calorifier Top	1
4	563905464	PS750 Unvented System	1
5	563906300	1 1/4" Magnesium Anode	1
6	563605492	PS750 Control Panel Kit	1
7	532104003	Bulb Retention Spring	2
8	744627332	1 1/2" To 1 1/4" Hex Bush	1
9	557002006	Thermometer	1
10	533806070	PS750 Flange Cover	1
11	563605534	Optional PTRY Discharge Pipe Kit	1
12	563605509	Re-Circulation Pump Kit	1
13	563605489	Series Flow Coupling Kit	1
14	530501014	Flange Adaptor for Immersion Element	1
15	531201148	Flange Gasket	1
16	748214340	M10x25 Hex HD Screw	10
17	744627340	1 1/4"x1" Hex Bush	1
18	533901347	Impressed Current Electrode	1
19	533901489	9kW Immersion Element	1
20	533901345	Potentiostat	1

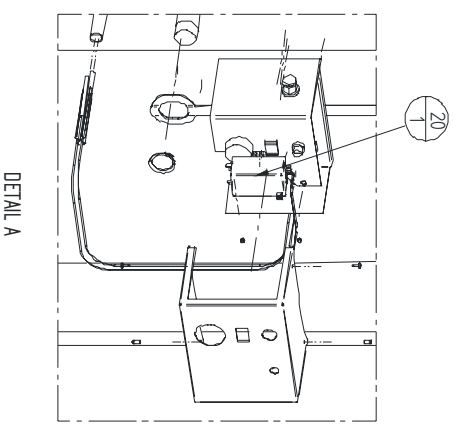

Figure 16.0 PS750 Assembly.

Item Number	Document Number	Title	Quantity
1	563906295	PS1000 Calorifier Vessel	1
2	533806071	PS1000 Top Cover	1
3	533806071	PS1000 Jacket	1
4	563906300	1/4" Magnesium Anode	1
5	563605510	PS1000 PTRV Kit	1
6	563605493	PS1000 Control Panel Assembly Kit	1
7	532104003	Bulb Retention Spring	2
8	563904225	1/2" To 1/4" Grounding Bush	1
9	563605510	Optional PTRV Discharge Pipework Kit	1
10	563605461	Re-circulation Pump Kit	1
11	563605489	Series Flow Coupling Kit	1
12	557002006	Thermometer	1
13	533806071	Flange Cover	1
14	531201148	PS750/1000 Flange Gasket	1
15	563906295	Clean Out Flange	1
16	748214340	M10x25 Hex HD Screw	10

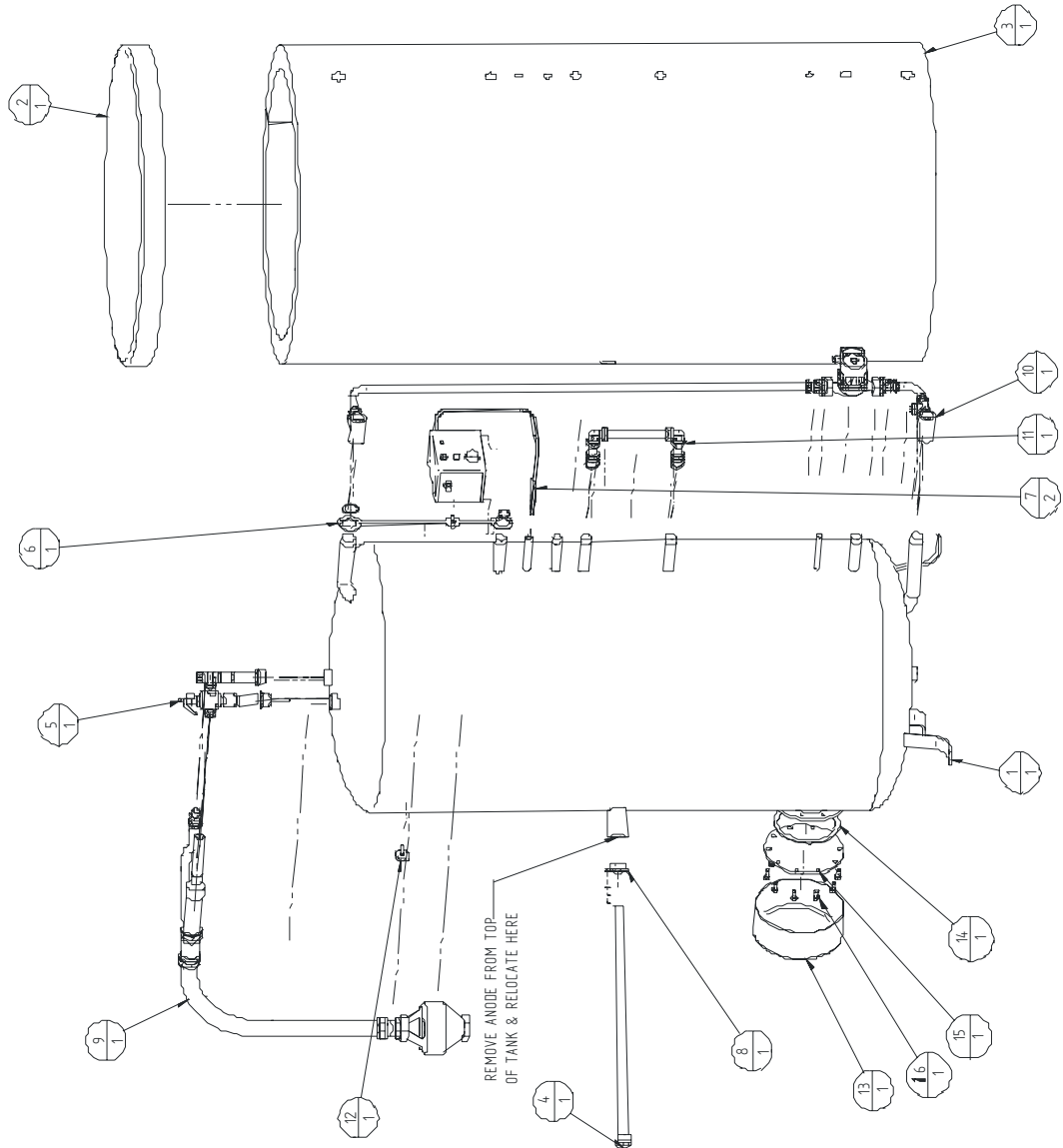

Figure 17.0 PS1000 Assembly.

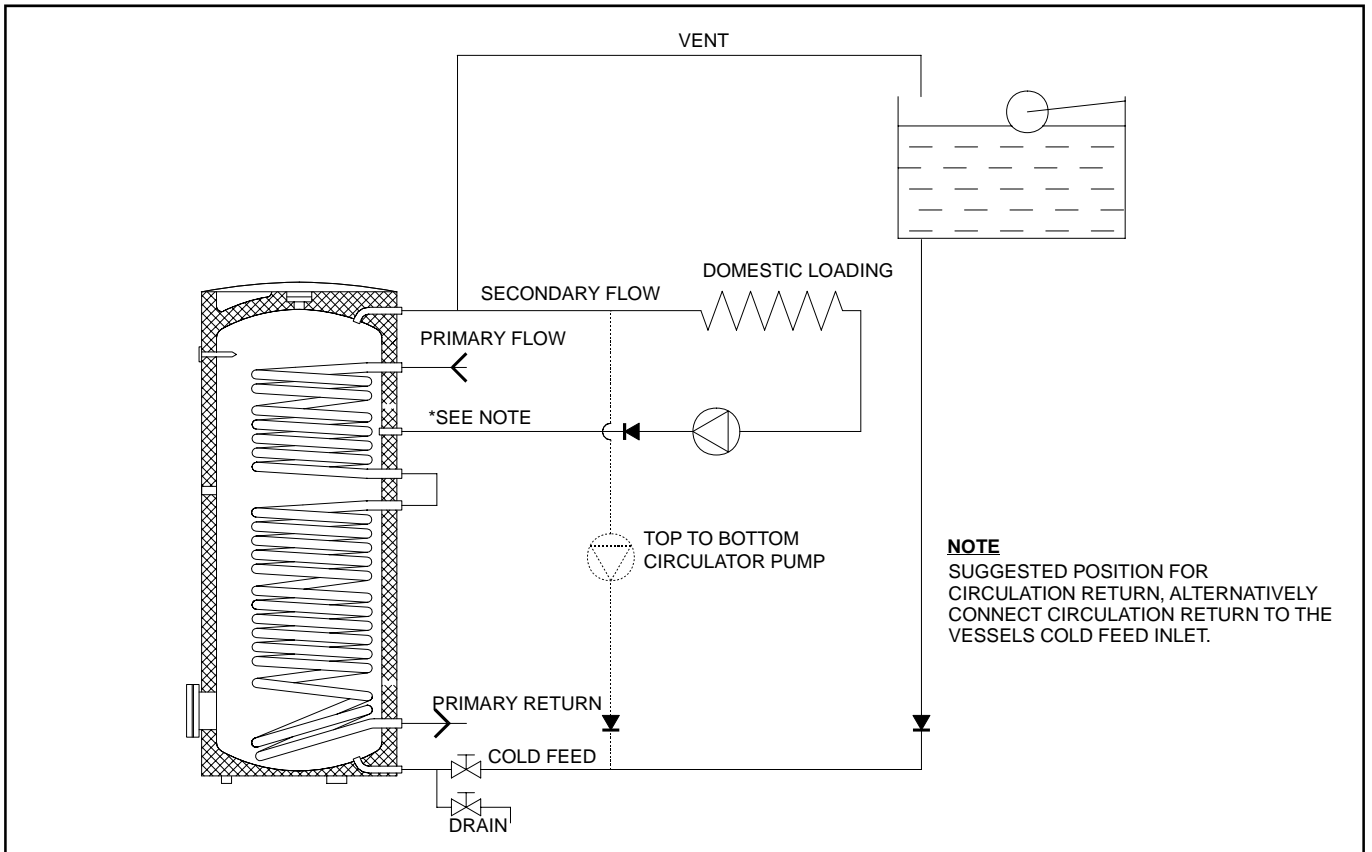

Figure 5.1 Hot Water Application: Single Calorifier (Vented System).

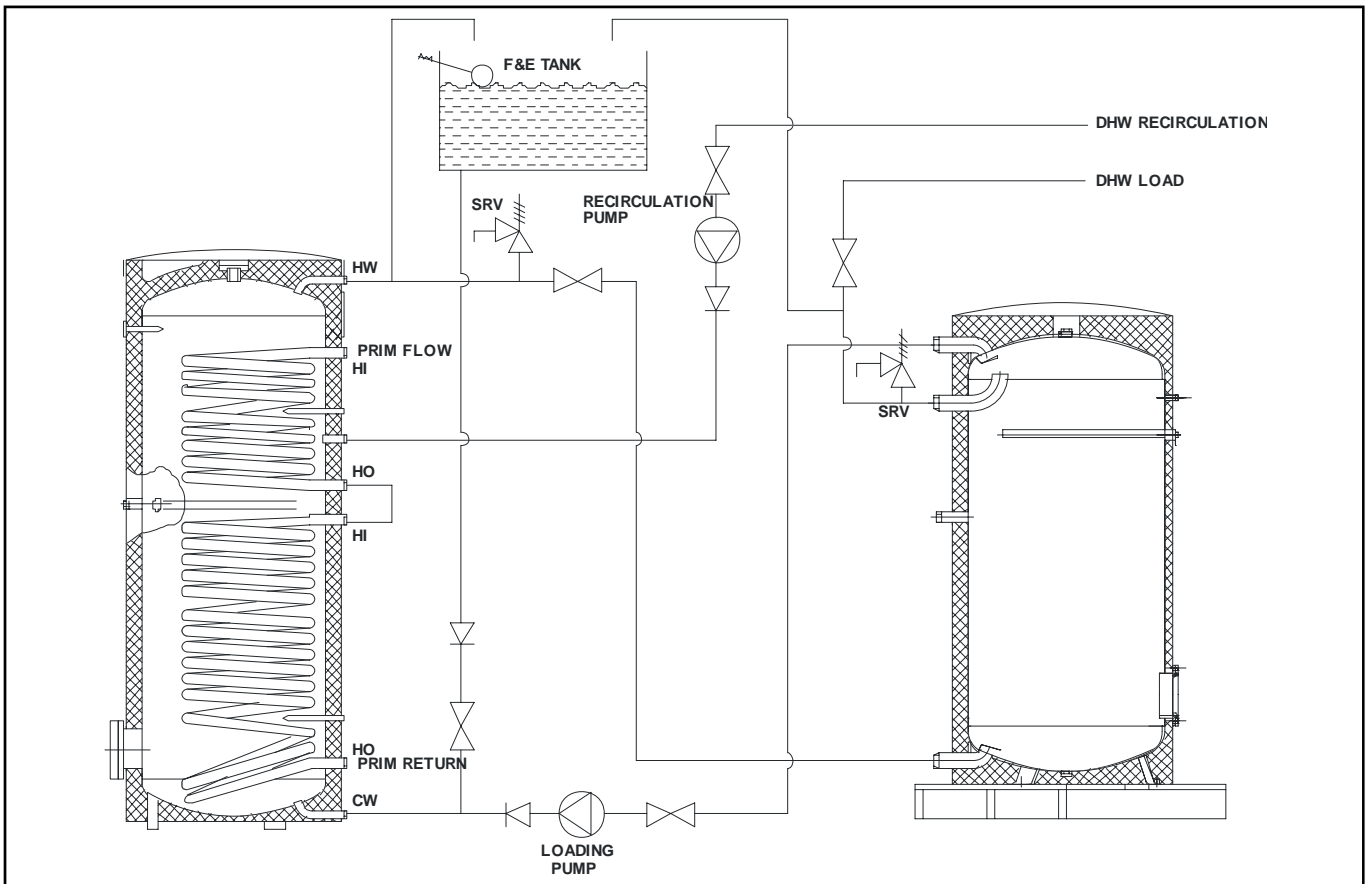

Figure 5.1 Hot Water Application: Combined Calorifier & Storage Tank (Vented System)

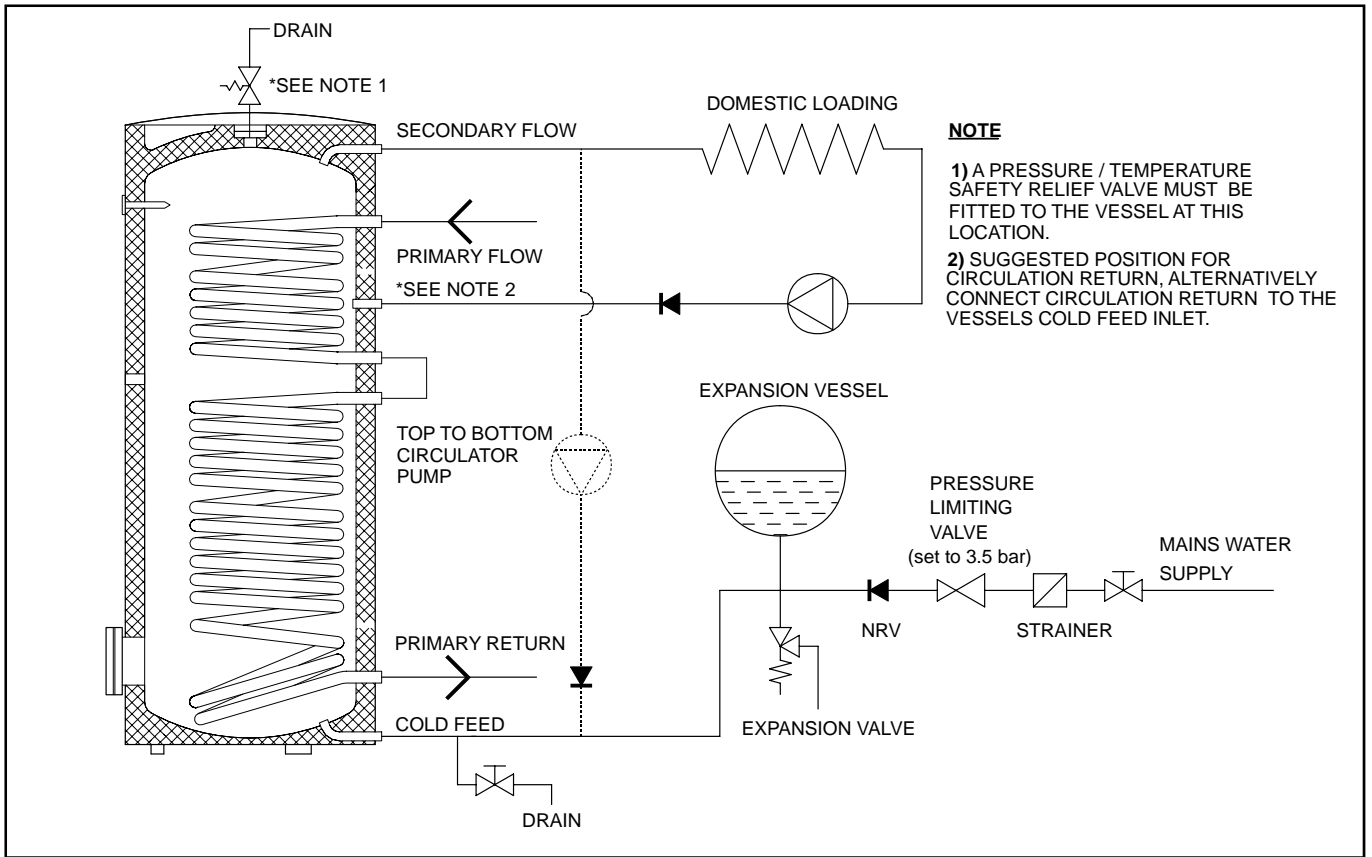

Figure 5.2 Hot Water Application: Single Calorifier (Un-Vented System).

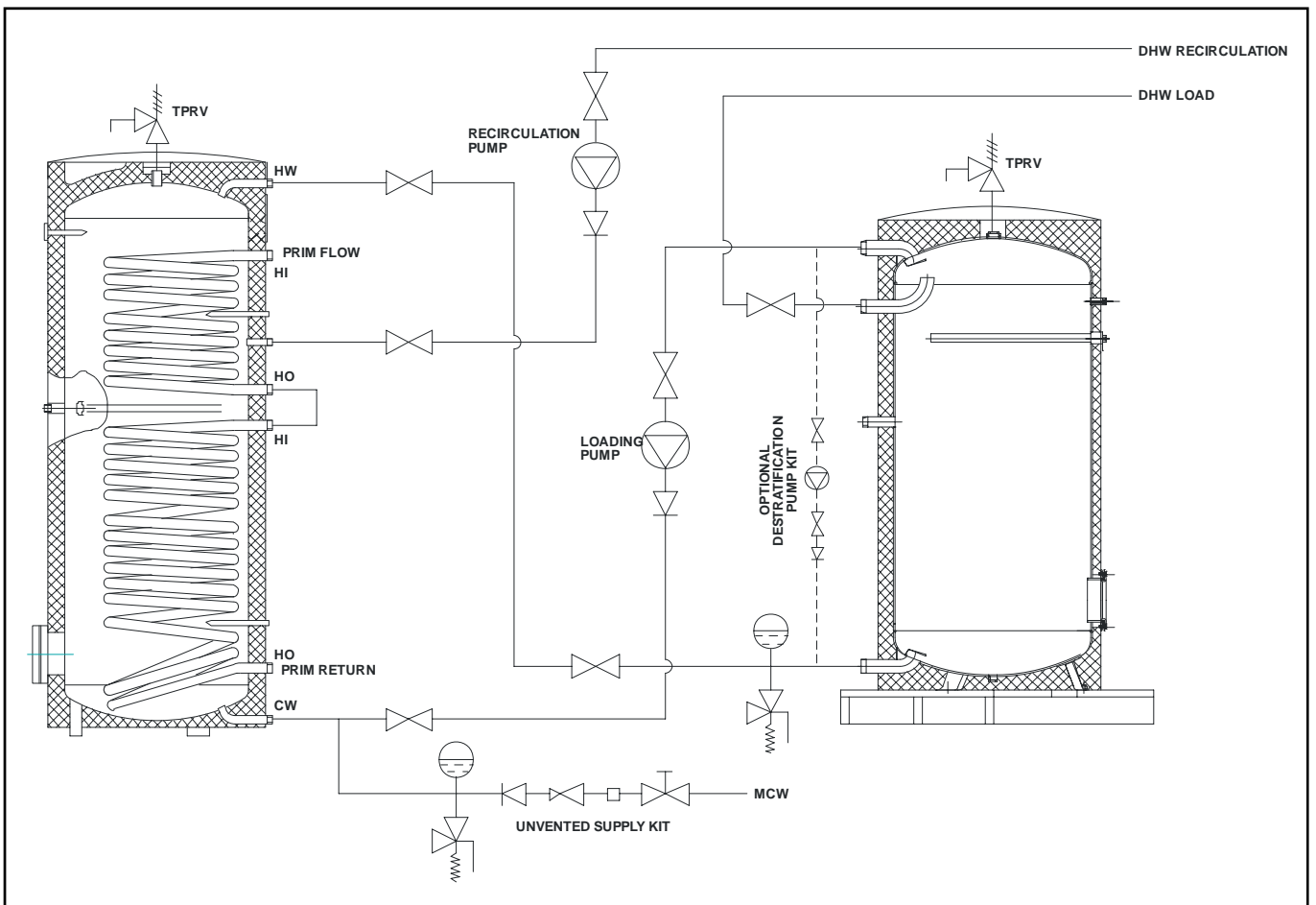

Figure 5.2 Hot Water Application: Combined Calorifier & Storage Tank (Un-Vented System).

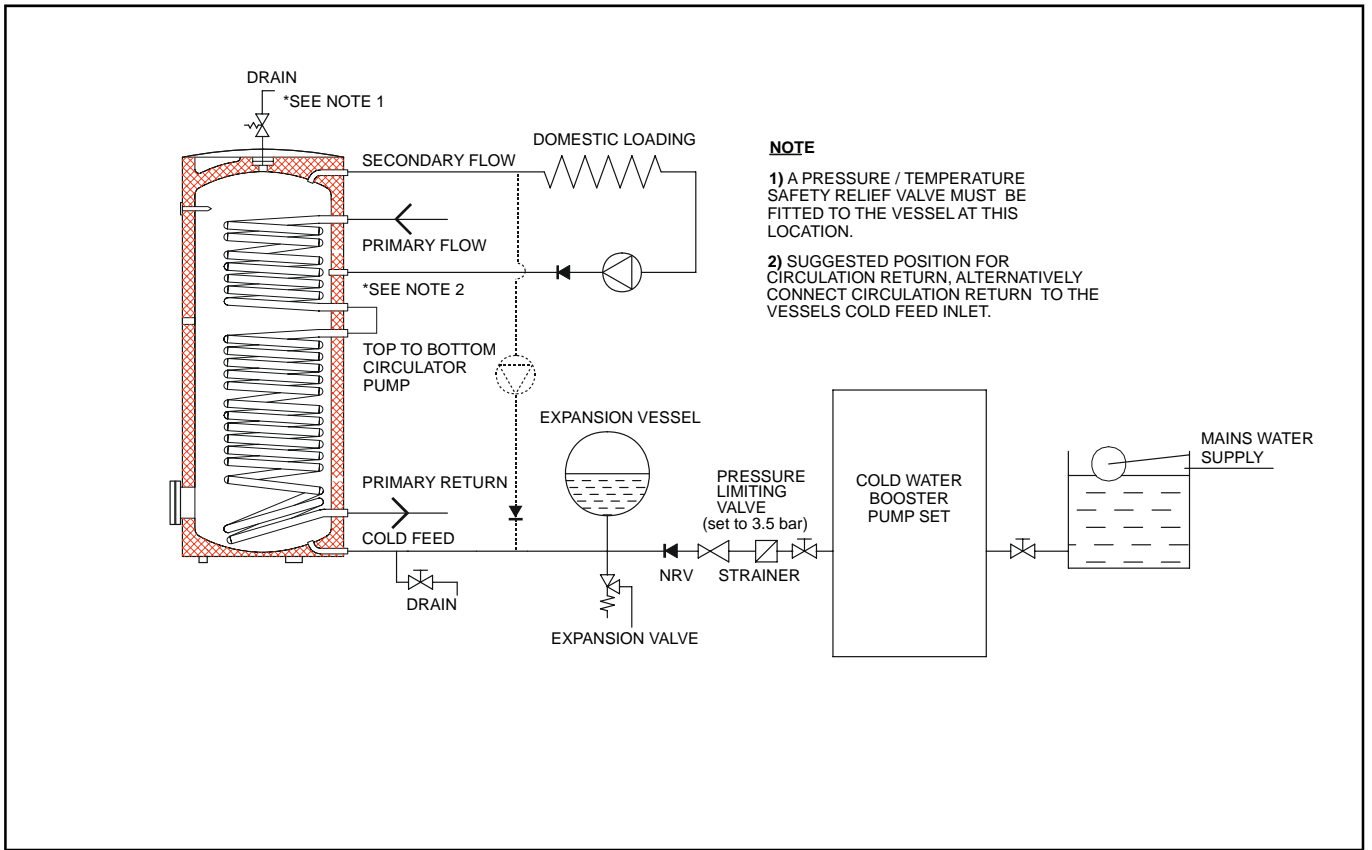

Figure 5.3 Hot Water Applications: Single Calorifer & Boosted system

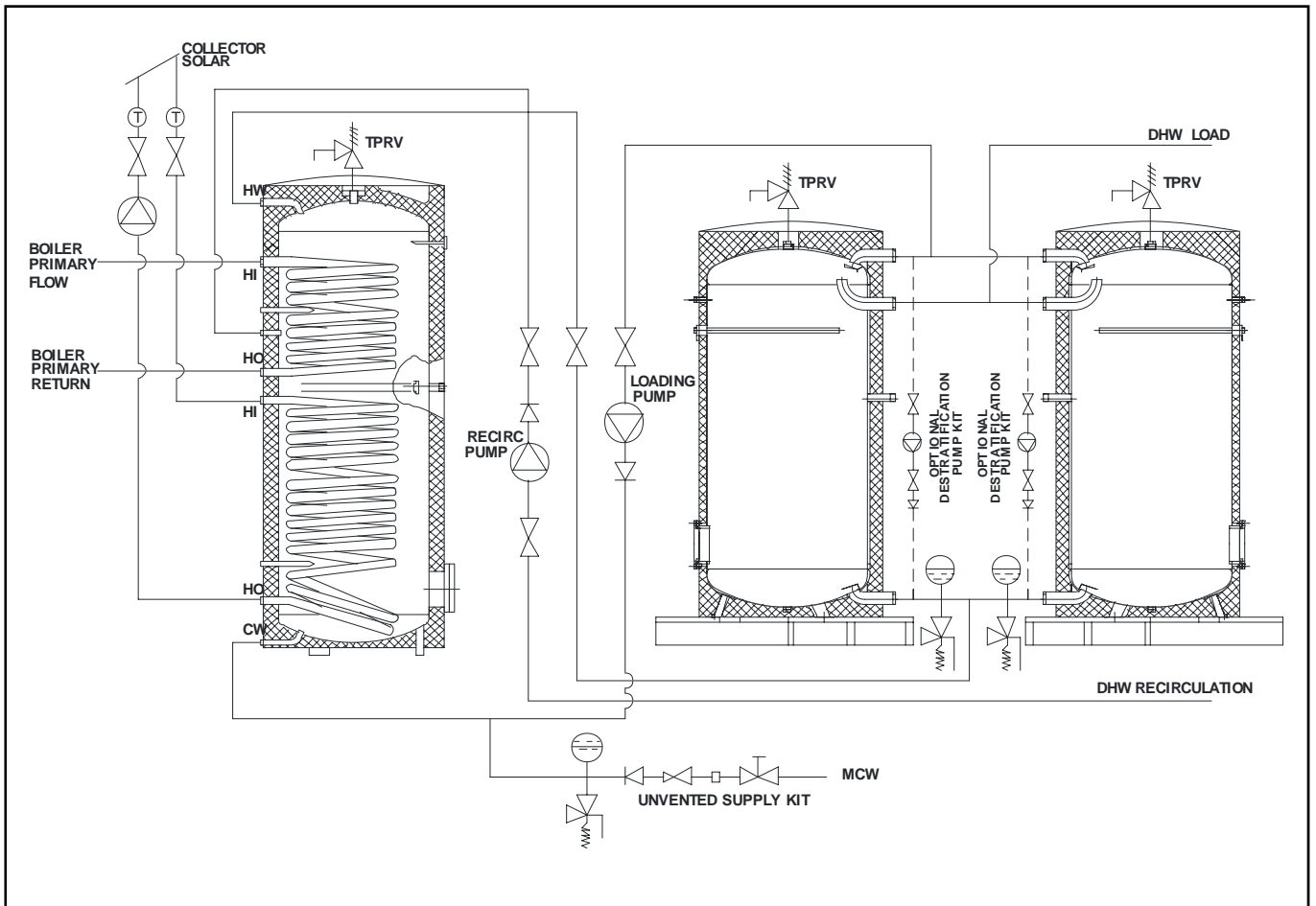

Figure 5.5 Hot water Application : Solar Preheat With Single Calorifer & Multiple Storage Tanks

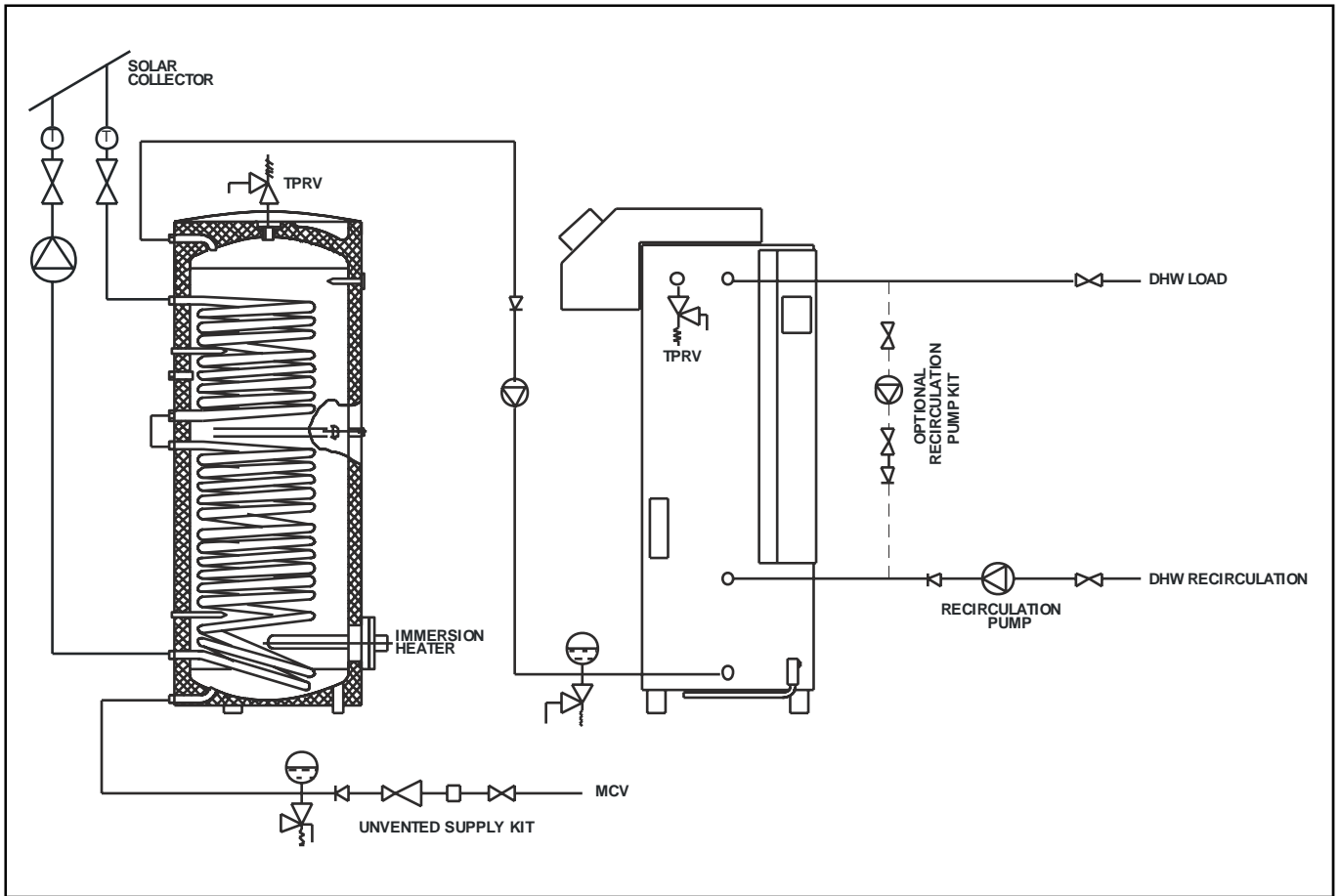

Figure 5.6 Hot Water Application: Solar Preheat Of Direct Fired Water Heater & Thermal Storage

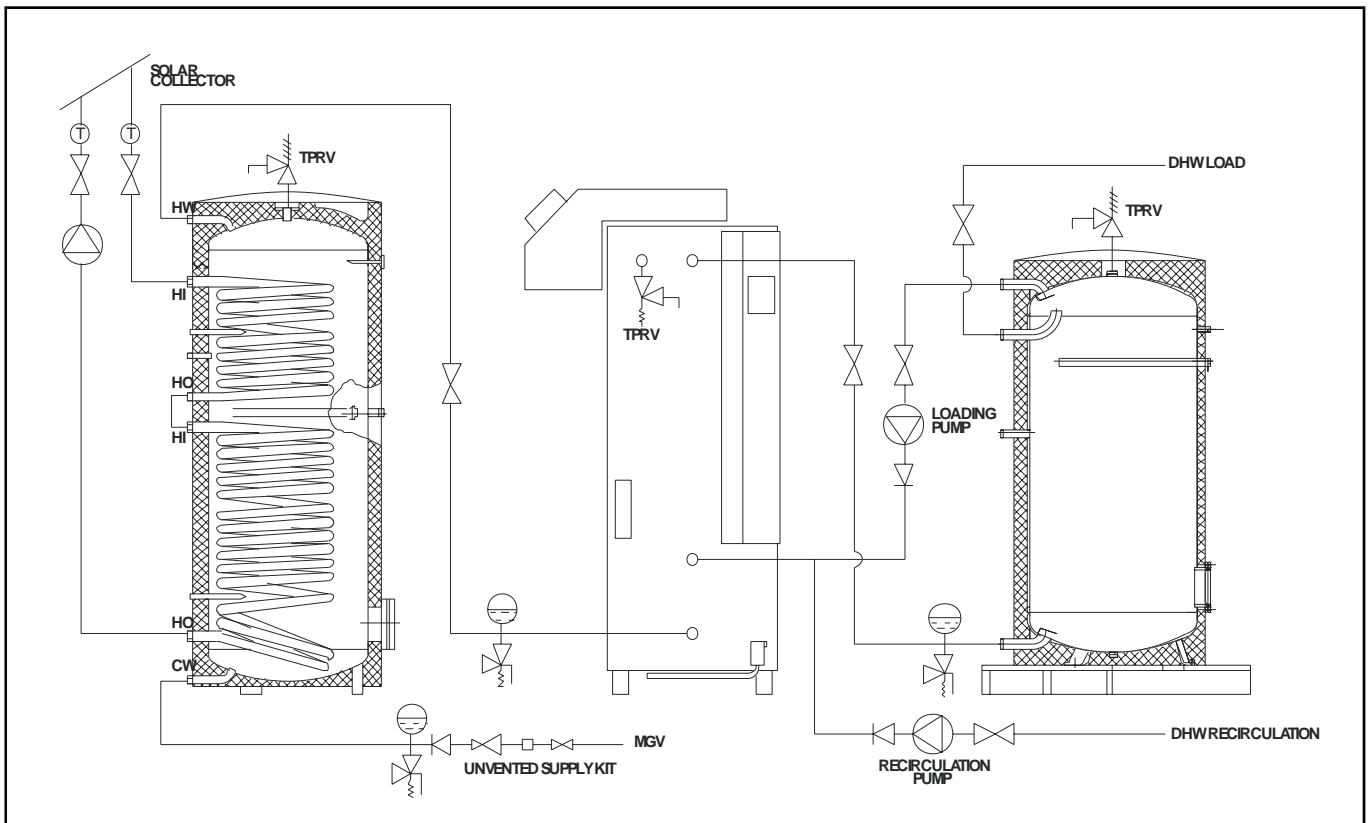

Figure 5.6 Hot Water Application : Solar Preheat Of Direct Fired Water Heater & Thermal Storage

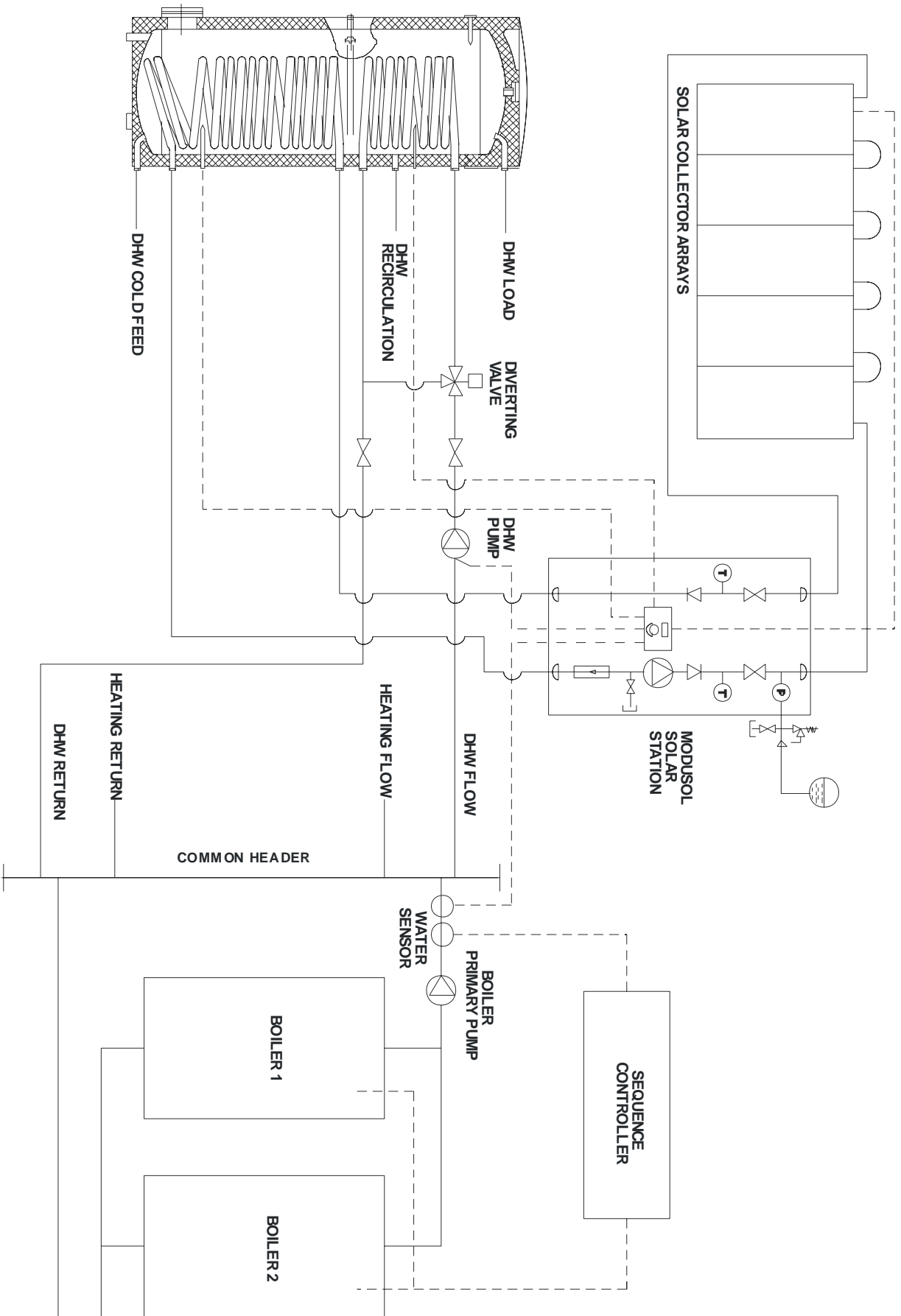

Figure 5.7 Hot Water Application : Solar Preheat With Auxiliary Heating

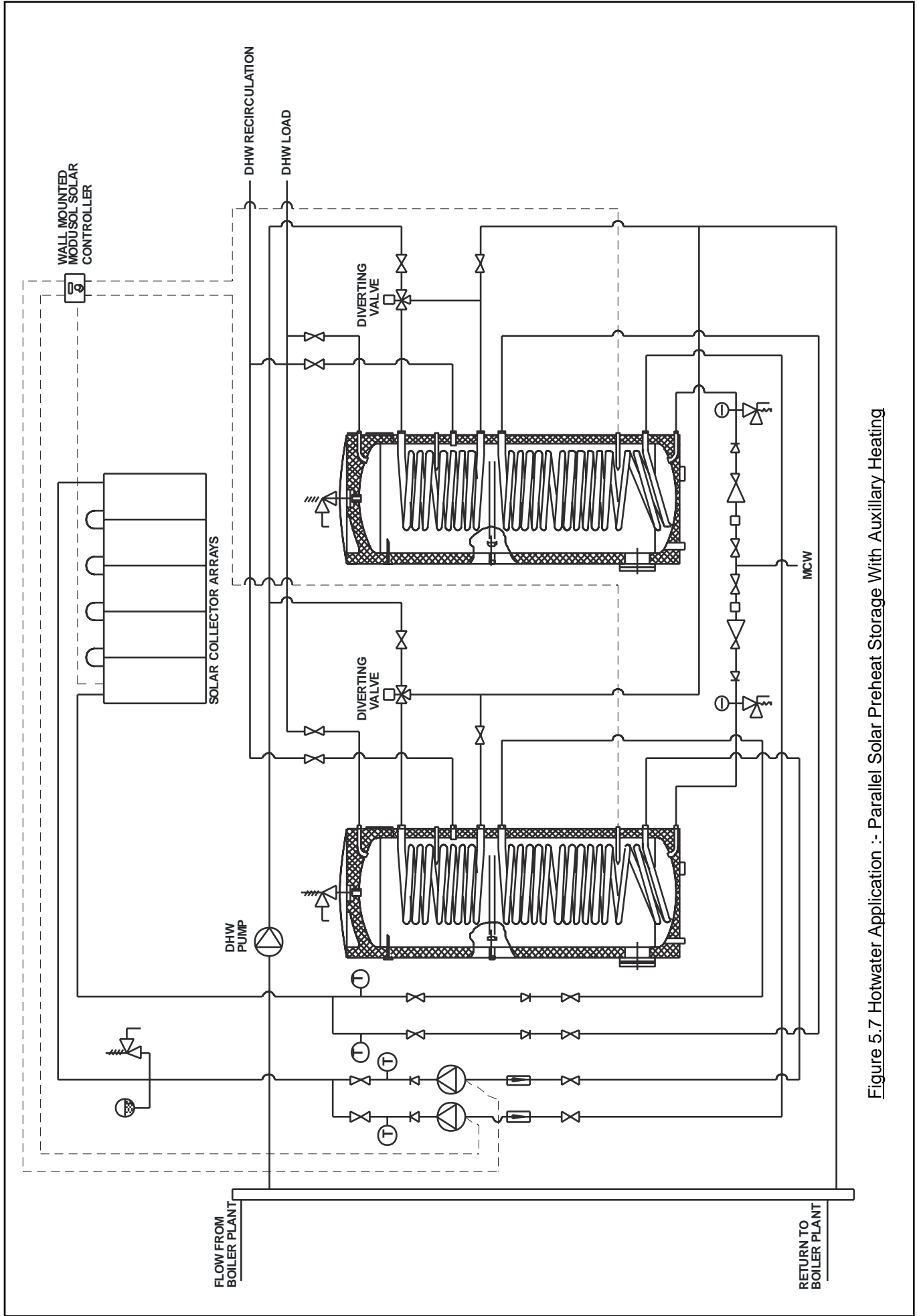

Figure 5.7 Hotwater Application :- Parallel Solar Preheat Storage With Auxilliary Heating

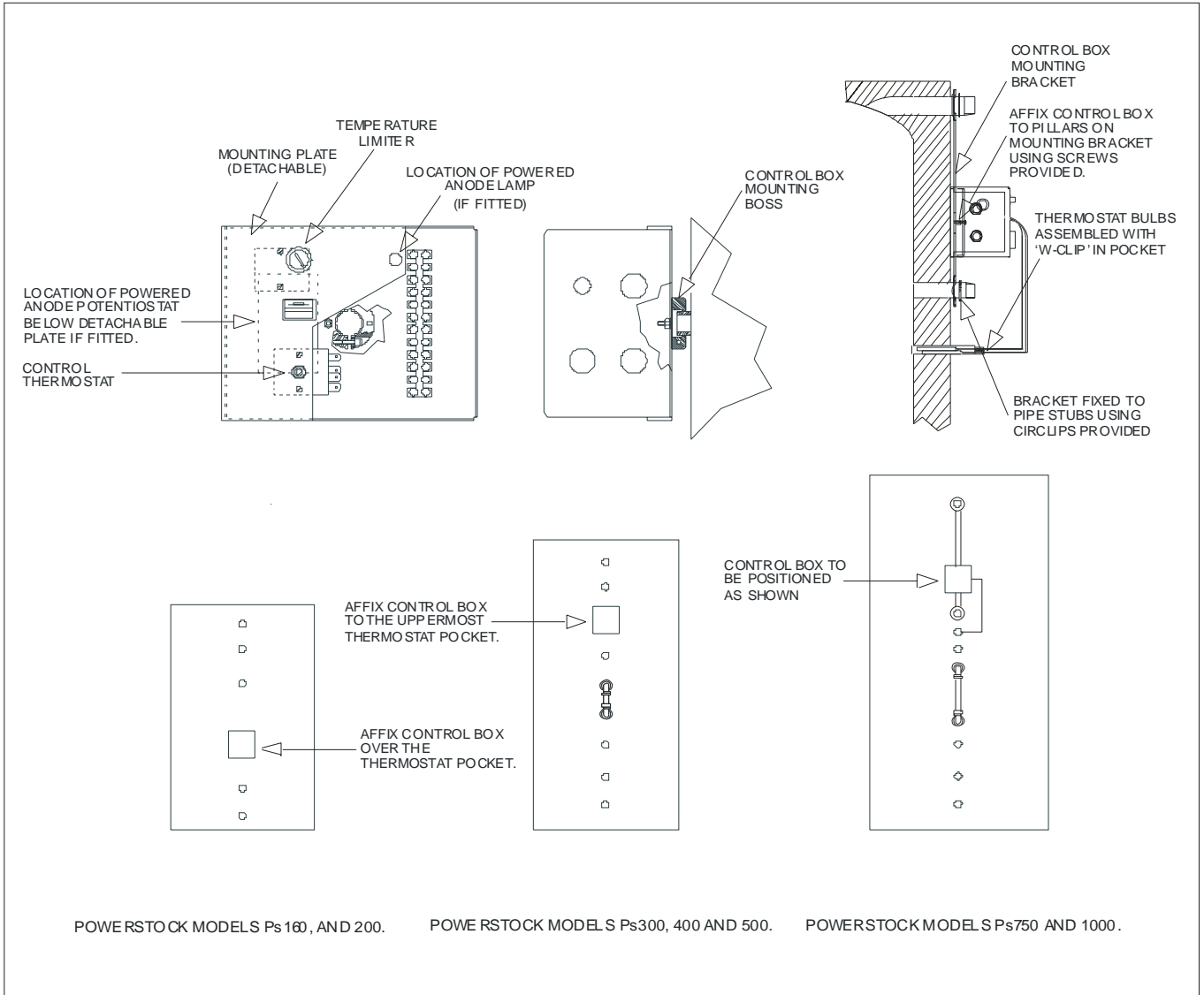

Figure 7.3 Control box layout.

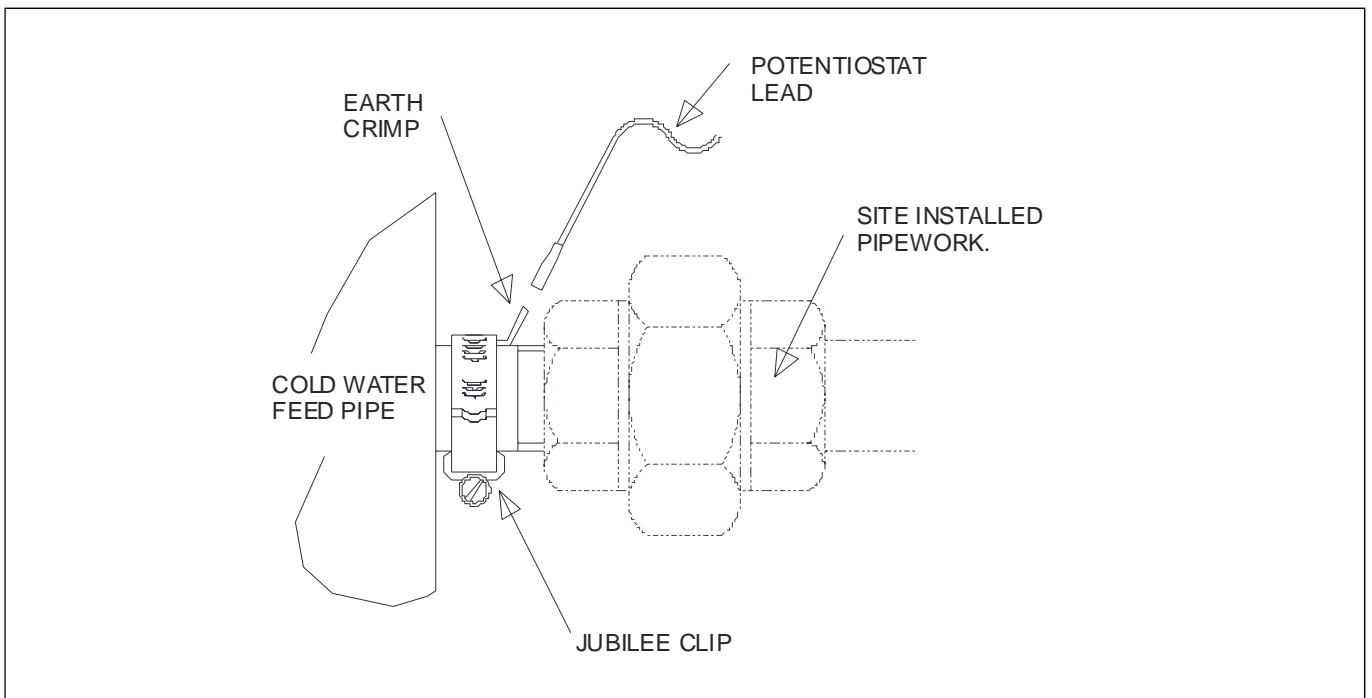
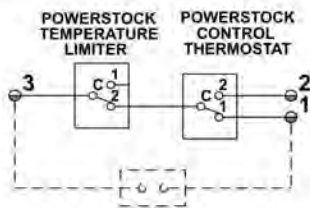

Figure 7.4 Earth tag assembly.

SIMPLE CONTROL SYSTEM.



BOILER REMOTE START/STOP TERMINALS

FOR SIMPLE CONTROL, NO MAINS ELECTRICAL SUPPLY IS CONNECTED TO THE "L" & "N" TERMINALS. TERMINALS 1 AND 3 ARE VOLT FREE EXCEPT WHEN SUPPLIED WITH SIGNAL VOLTAGE FROM THE BOILER VIA THE REMOTE START/STOP TERMINALS.

DIVERTER VALVE CONTROL.

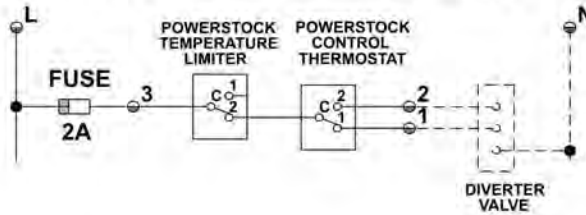

FOR DIVERTER VALVE CONTROL MAINS ELECTRICAL SUPPLY IS CONNECTED TO THE "L" & "N" TERMINALS. TERMINALS 1 & 2 PROVIDE SIGNAL VOLTAGE TO CONTROL VALVE ACTUATION.

BOILER CONTROL WITH CIRCULATOR PUMP.

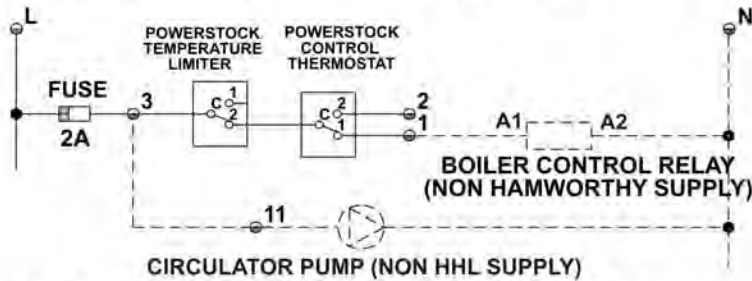

BOILER CONTROL WITH POWERED ANODE.

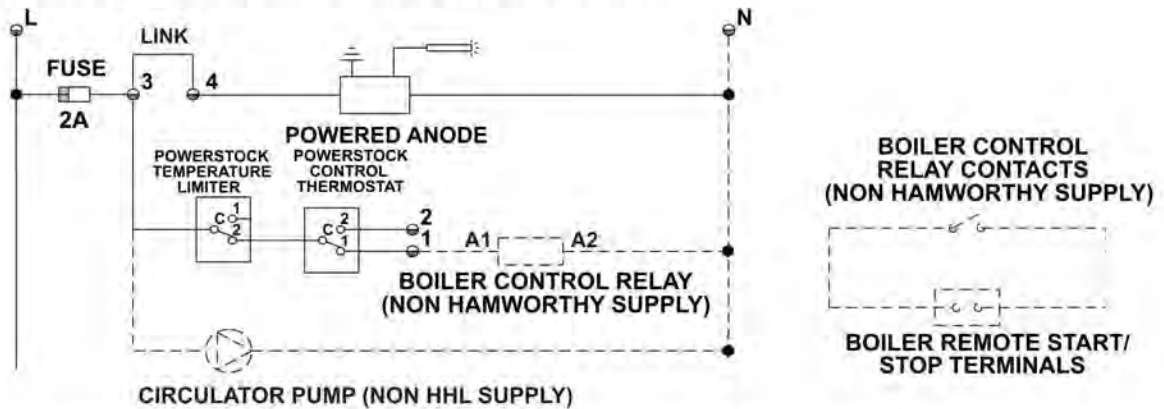

BOILER CONTROL WITH CIRCULATOR PUMP OR POWERED ANODE.

NOTE! THE BOILER MUST NOT BE DIRECTLY CONNECTED TO THE POWERSTOCK CONTROL BOX. THE COMMON AND NORMALLY CLOSED CONTROL CONTACTS ON THE BOILER CONTROL RELAY ARE OF THE VOLT FREE TYPE EXCEPT WHEN SUPPLIED VIA THE BOILER REMOTE START/STOP TERMINALS..

POWERSTOCK CONTROL BOX TERMINALS

----- CLIENTS WIRING

● TERMINAL No

Figure 6.2 Typical wiring of a Powerstock calorifier to a boiler.

IMMERSION HEATER CONTROL SYSTEM.

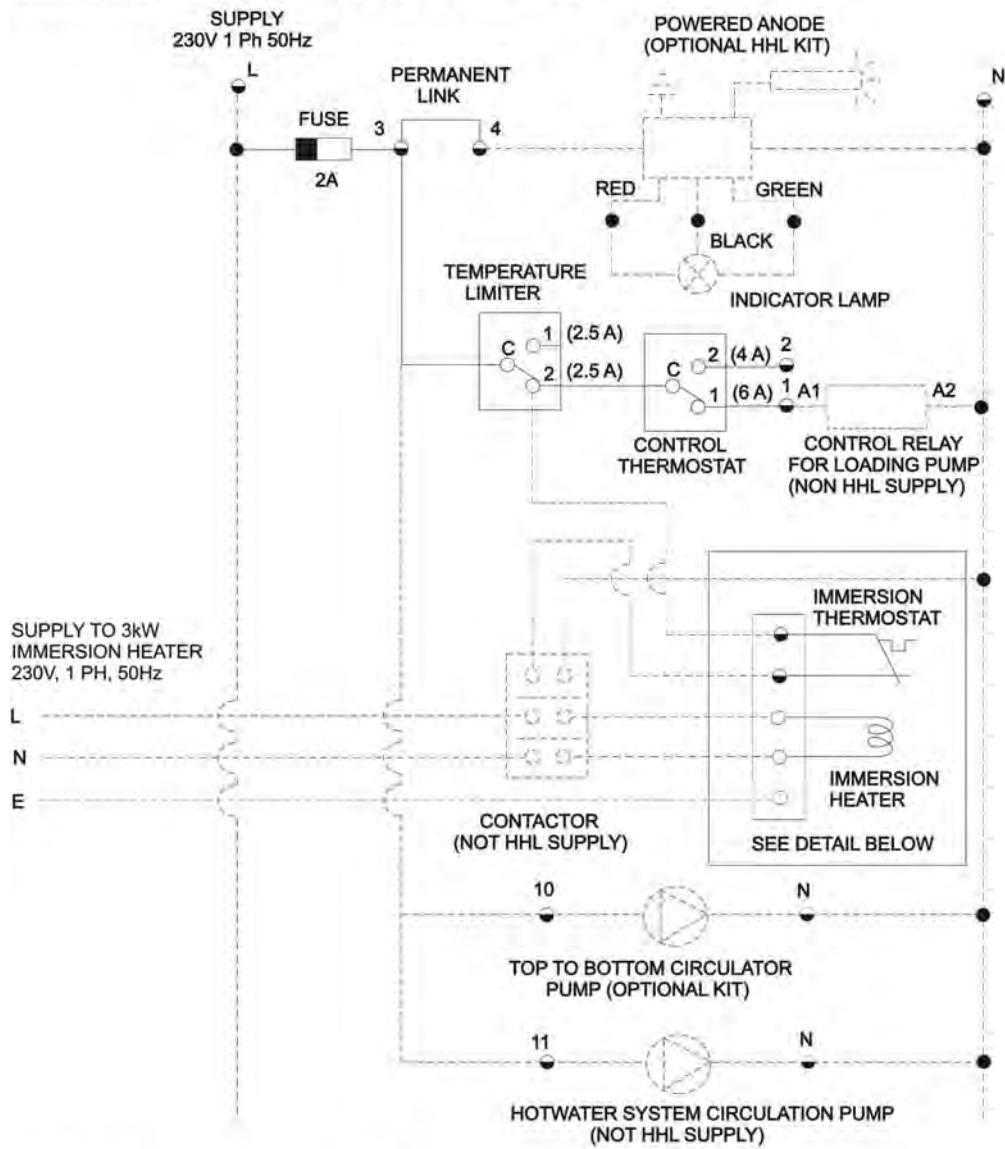

NOTE ! AN INTERRUPTED PERMANENT POWER SUPPLY IS REQUIRED FOR POWERED ANODE APPLICATIONS. WIRING CONNECTIONS FROM TERMINAL 3 TO TERMINALS 10 & 11 SHOULD BE MADE USING SUITABLY RATED CABLE. IF AN OPTIONAL IMMERSION HEATER IS FITTED, A SEPARATE POWER SUPPLY & APPROPRIATE CONTROL MUST BE PROVIDED.

IMMERSION HEATER WIRING CONNECTION.

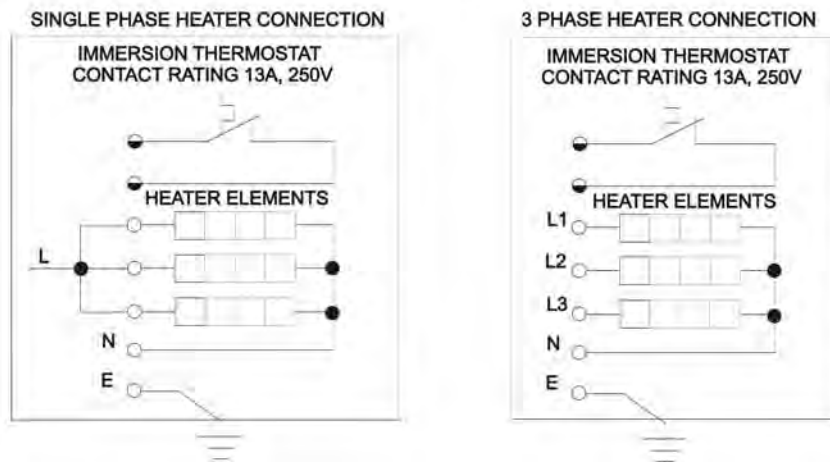

Figure 6.3 Typical Immersion Heater Control System For A Powerstock Calorifier.

IMMERSION HEATER RATING (kW)	HHL PART NUMBER	MINIMUM CONTACTOR CURRENT (A)	
		SINGLE PHASE	3 PHASE
4	533901393	16.7	5.6
9	533901489	37.5	12.5

Figure 6.4 - Table Of Minimum Contactor Current When Immersion Heaters Are Wired For Single & 3 Phase Supply

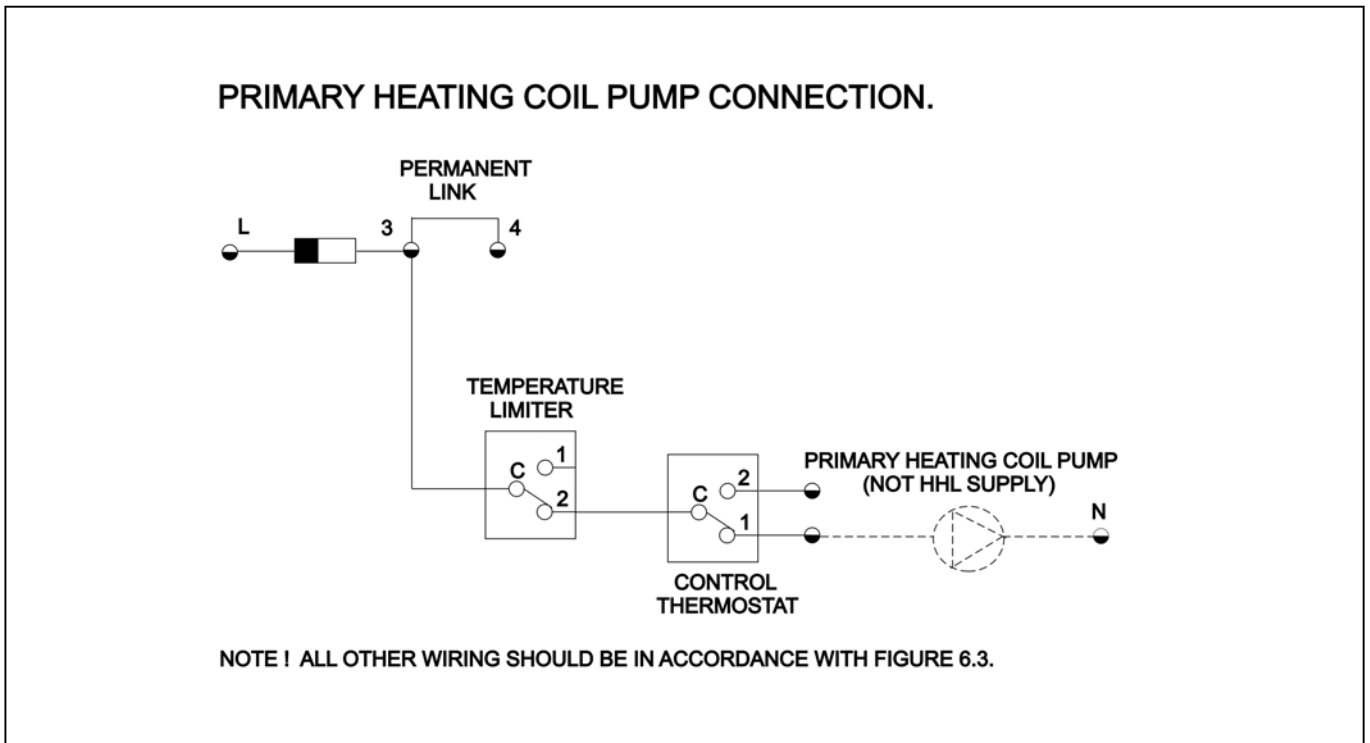

Figure 6.5 Wiring Schematic For Switching A Pump On The Primary Heating Coil Of The Calorifier.

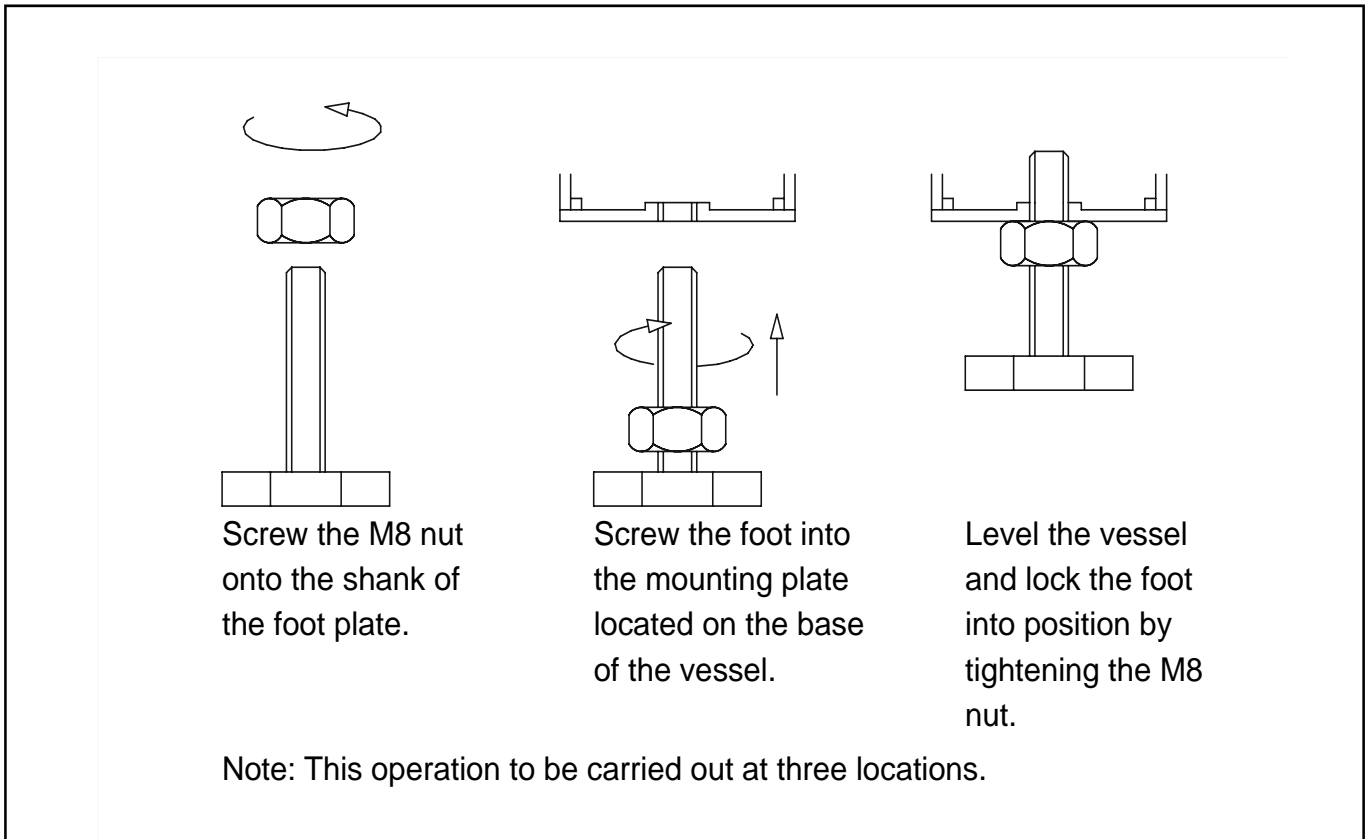

Figure 7.1 Leveling feet assembly

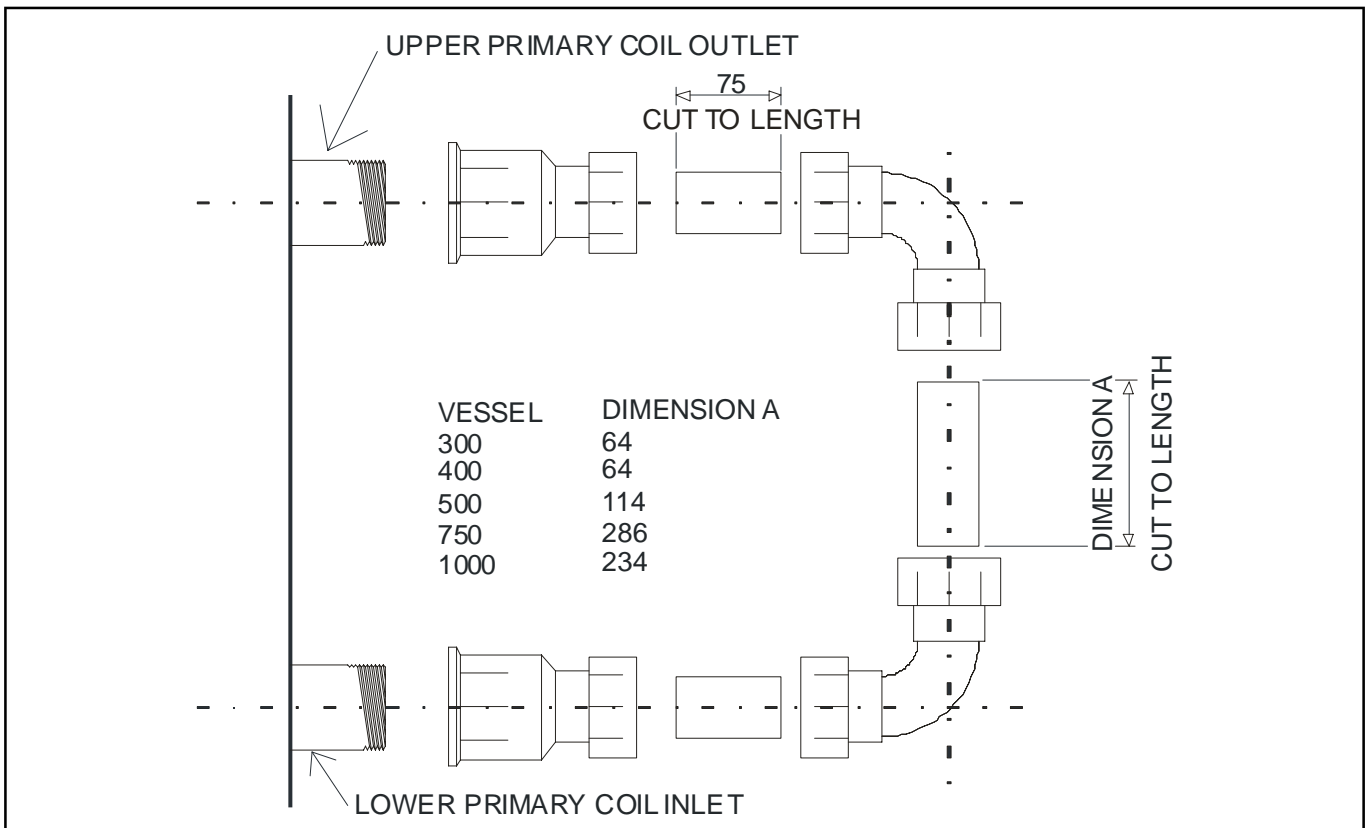
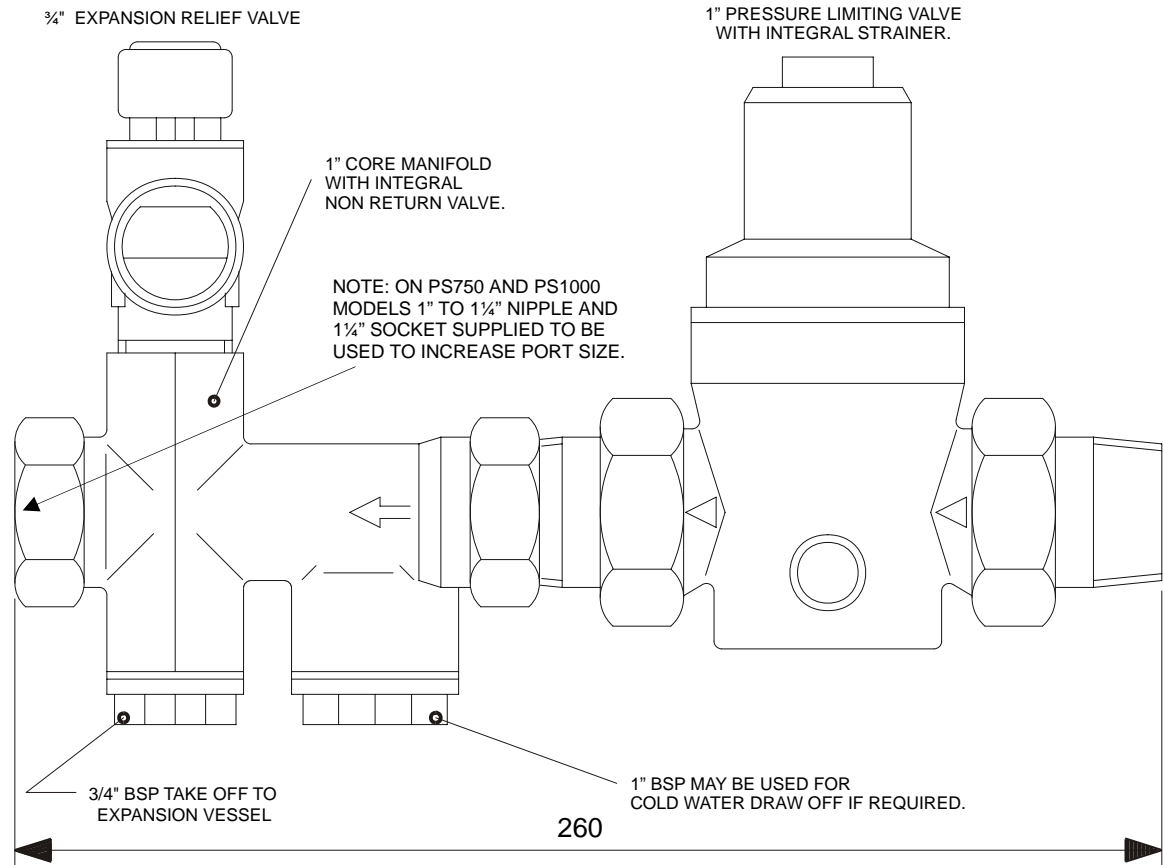

Figure 7.2.1 Coil connection (series flow) kit



Powerstock model	PS160	PS200	PS300	PS400	PS500	PS750	PS1000
Cold water feed side							
Pressure limiting valve (set to 3.5 bar) with integral strainer.	HHL PART No 531902006						
Expansion relief valve (set to 5 bar)	HHL PART No 531905003						
Check valve	HHL PART No 531911030						
1 1/4" Female Socket (Bronze)	Not required	Not required	Not required	Not required	Not required	741620345 1 off	741620345 1 off
1 1/4" to 1" Reducing Nipple (Bronze)	Not required	Not required	Not required	Not required	Not required	741617250 1 off	741617250 1 off
Expansion vessel HEL Part No	24 litre 532712082	24 litre 532712082	24 litre x 2 532712082	24 litre x 2 532712082	60 litre 532712058	80 litre 532712059	100 litre 532712060
Secondary hot water side							
Pressure temperature relief valve (set to 7 bar and 90°C +5 -0)	HHL PART No 531905004						

For PS160 to PS500 models quote HHL Ref: 562403076
 For PS750 to PS1000 models quote HHL Ref: 562403214

Figure No 7.2.3 Unvented applications

Note Before ordering clean out door gaskets determine the applicable flange type by reference to below.

Flange Dims	Vessel Type	
	PS 160 - PS 500	PS 750 & PS 1000
A	2 ¼ BSPT	2 ¼ BSPT
B	108	170
C	137	214
D	150	225
E	180	257

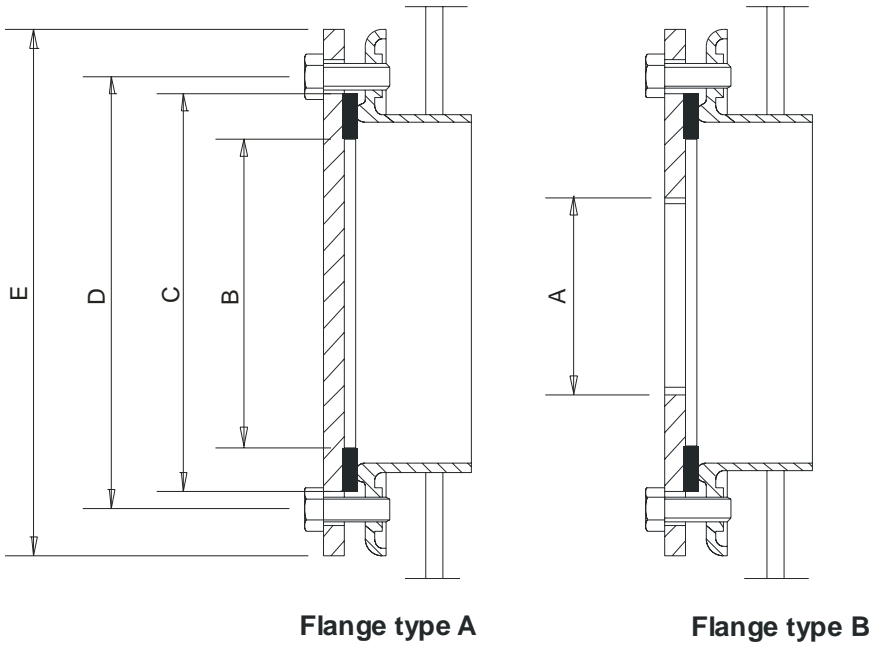
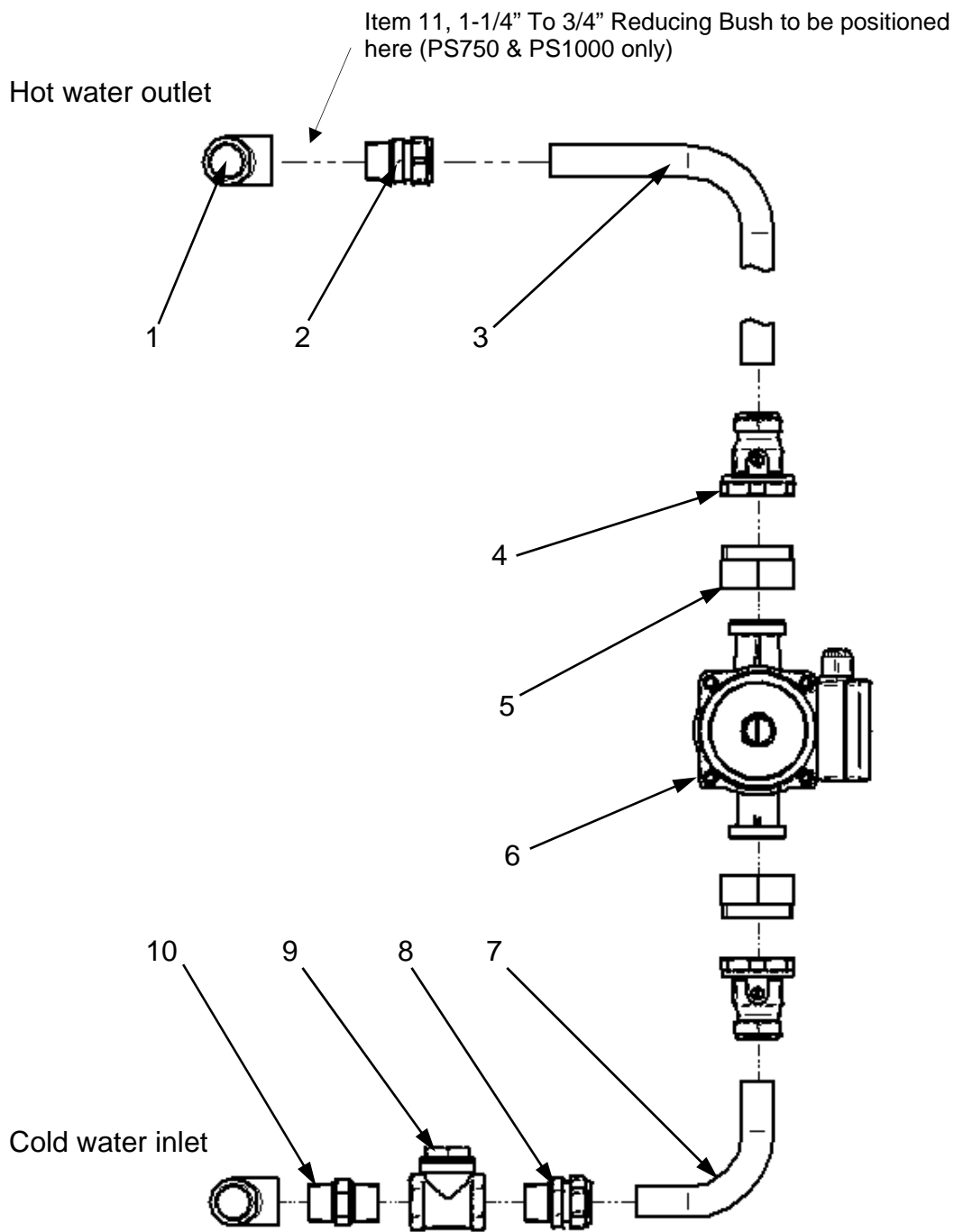

Figure 9.2 Clean out door flange.



Item	Description	Qty	PS160	PS200	PS300	PS400	PS500	PS750	PS1000
	Re-circulation kit		563605387	563605388	563605389	563605390	563605391	563605460	563605461
1	Tee	2	741654278	741654278	741654286	741654286	741654286	741654294	741654294
2	Coupling	1	530505002	530505002	530505128	530505128	530505128	530505128	530505128
3	Pipe 22mm	1	532403192	532403193	532403194	532403195	532403196	532403233	532403234
4	Isolation valve	2	531911002	531911002	531911002	531911002	531911002	531911002	531911002
5	Pump adaptor	2	530905047	530905047	530905047	530905047	530905047	530905047	530905047
6	Pump Biral WX13	1	1154050150	1154050150	1154050150	1154050150	1154050150	530905050	530905050
7	Elbow	1	532403011	532403011	532403011	532403011	532403011	532403011	532403011
8	Coupling	1	530505002	530505002	530505002	530505002	530505002	530505002	530505002
9	Check valve	1	531911003	531911003	531911003	531911003	531911003	531911003	531911003
10	Adaptor	1	741614298	741614298	741614298	741617085	741614298	741617101	741617101
11	Reducing Bush	1	-	-	-	-	-	741627340	741627340

Figure 10.1 Top to bottom circulation.

Notes

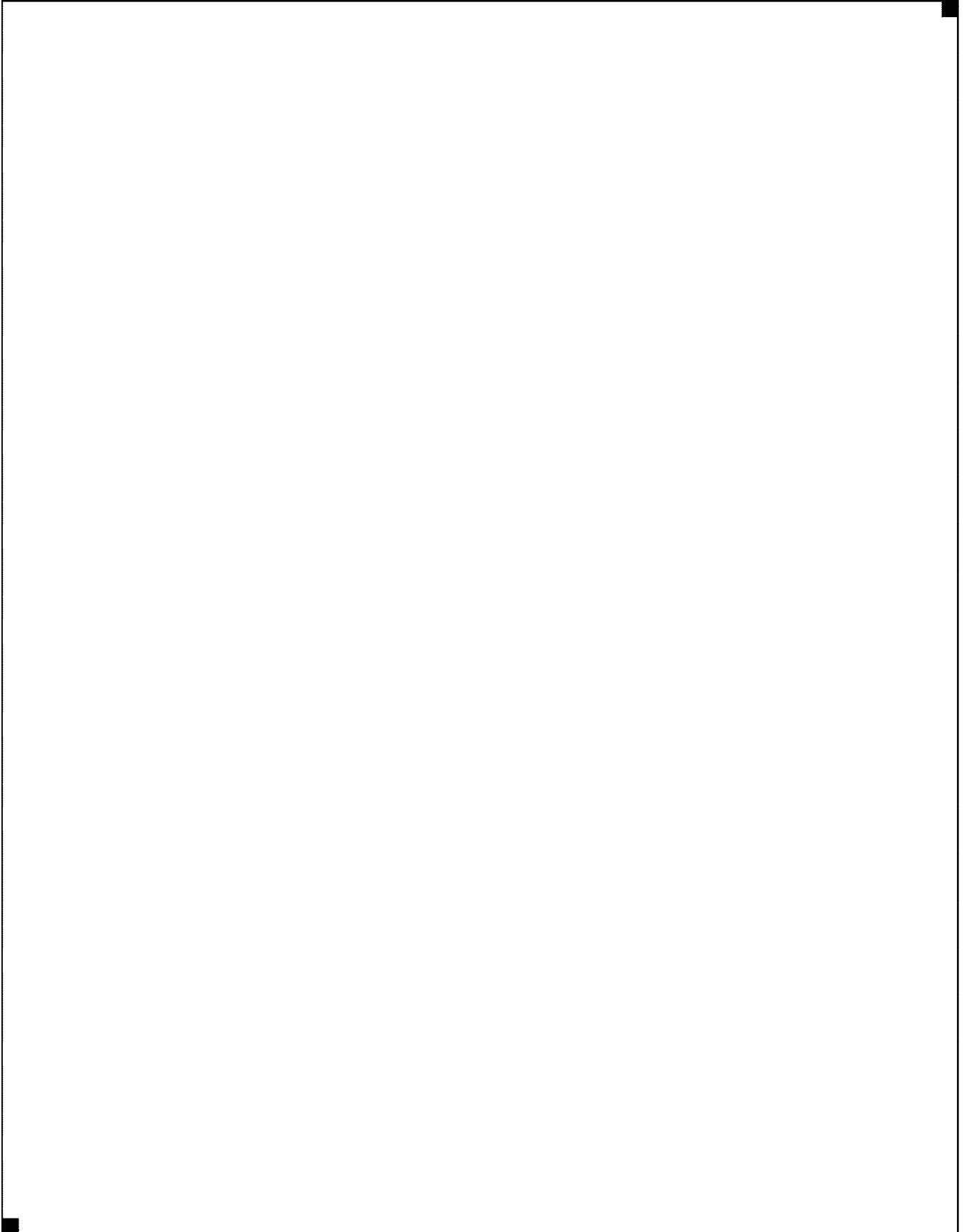
A large empty rectangular box with a black border, intended for notes. It has small black squares at the top-right and bottom-left corners.

Notes

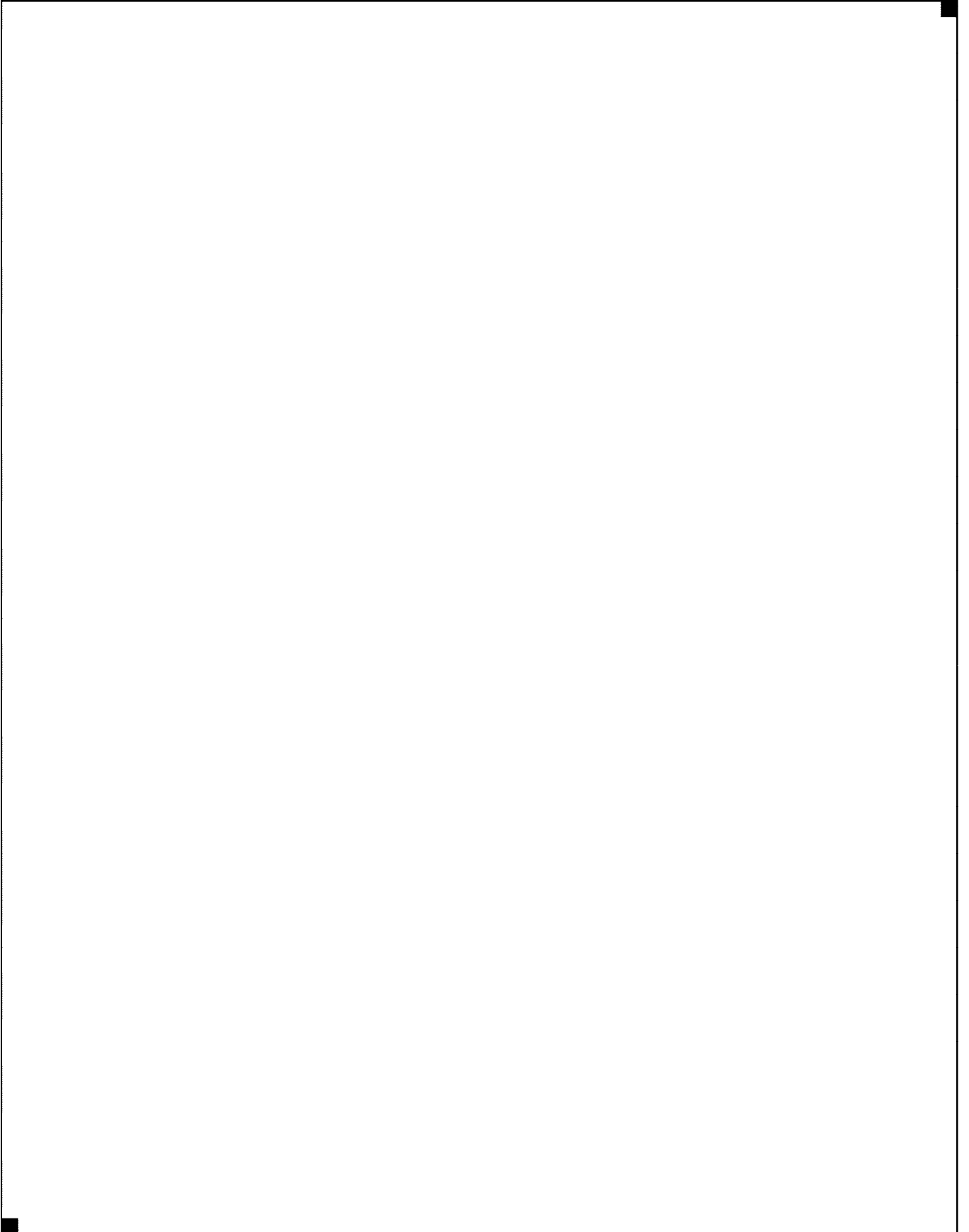
A large empty rectangular box with a black border, intended for notes. It has small black squares at the top-right and bottom-left corners.

Hamworthy Heating Accredited Agents

North West England

Gillies Modular Services
210-218 New Chester Road, Birkenhead, Merseyside L41 9BG
tel: **0151 666 1030** fax: **0151 647 8101**

Southern Ireland

HEVAC Limited
Naas Road, Dublin 12, Ireland
tel: **00 353 141 91919** fax: **00 353 145 84806**

Northern Ireland

HVAC Supplies Limited
Unit A6, Dargan Court, Dargan Crescent, Belfast BT3 9JP
tel: **02890 777737** fax: **02890 771233**

Scotland

McDowall Modular Services
14-46 Lomond Street, Glasgow, Scotland G22 6JD
tel: **0141 336 8795** fax: **0141 336 8954**

North East England

Allison Heating Products
12 Sunnyside Lane, Cleadon Village, Sunderland SR6 7XB
tel: **0191 536 8833** fax: **0191 536 9933**



Customer Service Centre

Hamworthy Heating Limited,
Fleets Corner, Poole,
Dorset BH17 0HH.

Telephone: **0845 450 2866**

Fax: **01202 662522**

Email: **aftersales@hamworthy-heating.com**

Website: **www.hamworthy-heating.com**